



**DB-1M, DB-2P
and DB-2A Dri-Block®
Operator's Manual**

Issue 21

Date of issue:

23rd July 2003.

Techne is the trade mark of

Techne and Techne Inc

© Techne 2002



Barloworld Scientific

CONTENTS

DB-1M, DB-2P and DB-2A Operator's Manual

	<i>page</i>
SAFETY and INSTALATION	
CE Declaration of Conformity	3
English	4
Français	6
Deutsch	8
Español	10
Italia	12
THE DRI-BLOCK®	14
Packing	15
Working Environment	15
SPECIFICATIONS	
DB-1M	16
DB-2P	17
DB-2A	18
OPERATION	19
Preparation	19
The overtemperature cutout	20
Setting the Pre-set Temperature	21
Setting the Operating Temperature	23
After Use	24
ADDITIONAL INFORMATION	25
Insert Blocks	25
Operator maintenance	26
Replacement parts	27

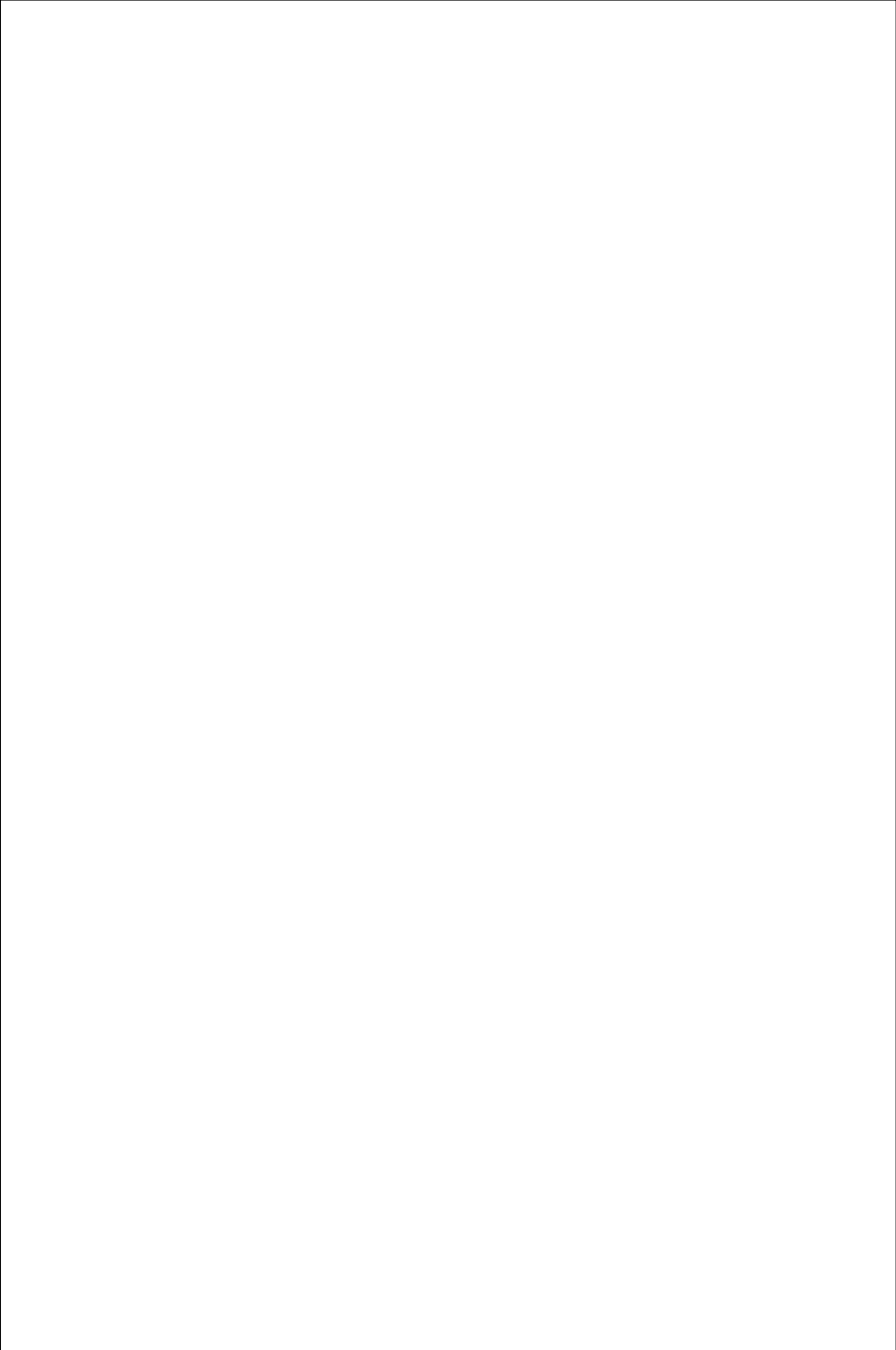



Techne
Duxford
Cambridge
CB2 4PZ



Declaration of Conformity

Techne Units DB-1M, DB-2P and DB-2A have been designed to comply with the following European Standards:

EN 50081-1:1992 Electromagnetic Compatibility; Generic emission standard.

EN 50082-1:1992 Electromagnetic Compatibility; Generic immunity standard (Performance criterion B).

EN 61010-1:1993 Safety requirements for electrical equipment for measurement, control and laboratory use.

EN 61010-2-010:1995 Particular requirements for laboratory equipment for the heating of materials.

I have made all reasonable enquiries regarding the unit stated and its conformance to the following EU directives.

Low Voltage directive, 73/23/EEC and amendment 93/68/EEC, and

EMC Directive 89/336/EEC and amendment 92/31/EEC.

To the best of my knowledge and belief these units conform to these directives.

This Declaration is controlled under an ISO 9001:2000 system certificated by BSI Quality Assurance, certificate number FM13585.

Signature

Name

B C Coombes

Position

Quality Manager

Issue 4

23/07/2003

Introduction

Please read all the information in this booklet before using the unit.

Warning

HIGH TEMPERATURES ARE DANGEROUS: they can cause serious burns to operators and ignite combustible material.

Techne have taken great care in the design of these units to protect operators from hazards, but Operators should pay attention to the following points:

- USE CARE AND WEAR PROTECTIVE GLOVES TO PROTECT HANDS;
- DO NOT put hot objects on or near combustible objects;
- DO NOT operate the unit close to inflammable liquids or gases;
- DO NOT place any liquid directly in your unit;
- At all times USE COMMON SENSE.

Operator Safety

All Operators of Techne equipment must have available the relevant literature needed to ensure their safety. It is important that only suitably trained personnel operate this equipment, in accordance with the instructions contained in this manual and with general safety standards and procedures. If the equipment is used in a manner not specified by Techne the protection provided by the equipment to the Operator may be impaired.

All Techne units have been designed to conform to international safety requirements and are fitted with an overtemperature cutout. On some models, the cutout is adjustable and should be set to suit the application. On all other models the cutout is preset to protect the unit.

If a safety problem should be encountered, switch off at the mains socket and remove the plug from the supply.

Installation

1. All Techne units are supplied with a power cable. This may be integral or plug-in.
2. Before connecting the mains supply, check the voltage against the rating plate. The rating plate is on the rear of the unit. Connect the mains cable to a suitable plug according to the table below.

Note that the unit must be earthed to ensure proper electrical safety.



<i>Connections</i>	<i>220V-240V</i>	<i>110V-120V</i>
Live	Brown	Black
Neutral	Blue	White
Earth	Green/yellow	Green

The fused plug supplied with the mains lead for use in the UK is fitted with the following value fuse to protect the cable: 5 AMP.

The fuse in the unit protects the unit and the operator

Note that units marked 230V on the rating plate work at 220V; units marked 120V work at 110V. In both cases, however, the heating rate will degrade by approximately 8%.

3. Plug the mains cable into the socket on the rear of the unit.
4. Place the unit on a suitable bench or flat workspace, or in a fume cupboard if required, ensuring that the air inlet vents on the underside are free from obstruction.
5. Note that the following symbols may be next to the indicator lamps on the front panel of the units and have the following meanings:

	:	the power indicator
	:	the heater indicator
	:	the overtemperature indicator

6. Symbols on or near the power switch of the unit have the following meanings:

I	:	mains switch On
O	:	mains switch Off

After use

When you have finished heating samples, remember that parts of the unit – the tubes, blocks and associated accessories – may be very hot. Take the precautions listed earlier.

Guarantee

The unit is guaranteed against any defect in material or workmanship for the period specified on the enclosed guarantee card. This period is from the date of purchase, and within this period all defective parts will be replaced free of charge provided that the defect is not the result of misuse, accident or negligence. Servicing under this guarantee should be obtained from the supplier.

Notwithstanding the description and specification(s) of the units contained in the Operator's Manual, Techne hereby reserves the right to make such changes as it sees fit to the units or to any component of the units.

This Manual has been prepared solely for the convenience of Techne customers and nothing in this Instruction Book shall be taken as a warranty, condition or representation concerning the description, merchantability, fitness for purpose or otherwise of the units or components.

Operator maintenance

NOTE: THAT THIS EQUIPMENT SHOULD ONLY BE DISMANTLED BY PROPERLY TRAINED PERSONNEL.

REMOVING THE SIDE, FRONT OR REAR PANELS EXPOSES POTENTIALLY LETHAL MAINS VOLTAGES.

THERE ARE NO OPERATOR MAINTAINABLE PARTS WITHIN THE EQUIPMENT.

In the unlikely event that you experience any problems with your unit which cannot easily be remedied, you should contact your supplier and return the unit if necessary. Please include any details of the fault observed and remember to return the unit in its original packing. Techne accept no responsibility for damage to units which are not properly packed for shipping; if in doubt, contact your supplier. See the Decontamination Certificate supplied with your unit.

1. Cleaning

Before cleaning your unit ALWAYS disconnect it from the power supply and allow it to cool below 50° C.

Your unit can be cleaned by wiping with a damp soapy cloth. Care should be exercised to prevent water from running inside the unit. Do not use abrasive cleaners.

2. Overtemperature cutout

In the event of no heater power, check the mains plug and lead. Repeated operation of the cutout indicates a serious fault: you may need to return the unit to your supplier for repair.

3. Fuses

Your unit is protected by one or two fuses. These should only be changed by suitably qualified personnel. If the fuses blow persistently, a serious fault is indicated and you may need to return the unit to your supplier for repair.

Contact Information

For technical, sales or servicing information, contact your local Techne dealer or,

Techne, Duxford,

Cambridge, CB2 4PZ, United Kingdom.

Telephone: +44(0)1223 832401

Fax: +44(0)1223 836838

Service: +44(0)1223 836950 Out of office hours

e-mail: sales@techne.com

Web site: www.techne.com

or,

Techne Inc, 3 Terri Lane,

Suite 10, Burlington,

New Jersey 08016, USA.

Telephone: 609-589-2560

Toll free: 800-225-9243 ext 306

Fax: 609-589-2571

e-mail: labproducts@techneusa.com

Web site: www.techneusa.com

Introduction

Veillez lire attentivement toutes les instructions de ce document avant d'utiliser l'appareil.

Avertissement

DANGER DE TEMPERATURES ELEVEES : les opérateurs peuvent subir de graves brûlures et les matériaux combustibles risquent de prendre feu.

Techne a apporté un soin tout particulier à la conception de ces appareils de façon à assurer une protection maximale des opérateurs, mais il est recommandé aux utilisateurs de porter une attention spéciale aux points suivants :

- PROCEDER AVEC SOIN ET PORTER DES GANTS POUR SE PROTEGER LES MAINS.
- NE PAS poser d'objets chauds sur ou près de matériaux combustibles.
- NE PAS utiliser l'appareil à proximité de liquides ou de gaz inflammables.
- NE PAS verser de liquide directement dans l'appareil.
- FAIRE TOUJOURS PREUVE DE BON SENS.

Sécurité de l'opérateur

Tous les utilisateurs de produits Techne doivent avoir pris connaissance des manuels et instructions nécessaires à la garantie de leur sécurité.

Important : cet appareil doit impérativement être manipulé par un personnel qualifié et utilisé selon les instructions données dans ce document, en accord avec les normes et procédures de sécurité générales. Dans le cas où cet appareil ne serait pas utilisé selon les consignes précisées par Techne, la protection pour l'utilisateur ne serait alors plus garantie.

Tous les appareils Techne sont conçus pour répondre aux normes de sécurité internationales et sont dotés d'un coupe-circuit en cas d'excès de température. Sur certains modèles, ce coupe-circuit est réglable pour s'adapter à l'application désirée. Sur d'autres modèles, il est pré-réglé en usine pour assurer la protection de l'appareil.

Dans le cas d'un problème de sécurité, coupez l'alimentation électrique au niveau de la prise murale et enlevez la prise connectée à l'appareil.

Installation



1. Tous les appareils Techne sont livrés avec un câble d'alimentation qui peut être intégré à l'appareil ou à raccorder.
2. Avant de brancher l'appareil, vérifiez la tension requise indiquée sur la plaque d'identification. Raccordez le câble électrique à la prise appropriée en vous reportant au tableau ci-dessous. **Il est important que l'appareil soit relié à la terre pour assurer la protection électrique requise.**

<i>Connexions</i>	220V-240 V	110V-120 V
Phase	marron	noir
Neutre	bleu	blanc
Terre	vert/jaune	vert



Le fusible à l'intérieur de l'appareil est destiné à assurer la protection de l'appareil et de l'opérateur.

Remarque : les appareils dont la plaque indique 230 V peuvent fonctionner sur 220 V, et ceux dont la plaque indique 120 V peuvent fonctionner sur 110 V. Dans les deux cas cependant, la capacité de chauffage diminuera d'environ 8 %. La plaque d'identification se trouve à l'arrière de l'appareil.

3. Raccordez le câble d'alimentation à la prise située à l'arrière de l'appareil.
4. Placez l'appareil sur un plan de travail ou surface plane, ou le cas échéant, dans une hotte d'aspiration, en s'assurant que les trous d'aération situés sous l'appareil ne soient pas obstrués.
5. Les symboles ci-dessous situés à côté des témoins lumineux sur la face avant de l'appareil ont la signification suivante :

	: témoin d'alimentation
	: témoin de chauffage
	: témoin d'excès de température

6. Les symboles situés sur ou à côté de l'interrupteur de l'appareil ont la signification suivante :

	: arrêt
	: marche

Après utilisation

Lorsque vous avez fini de chauffer les échantillons, n'oubliez pas que certaines parties de l'appareil - les éprouvettes, leurs supports et autres accessoires - risquent d'être très chaudes. Il est donc recommandé de toujours prendre les précautions citées plus haut.

Garantie

L'appareil est garanti contre tout défaut ou vice fabrication pour la durée figurant sur la carte de garantie, à compter de la date d'achat de l'appareil. Au cours de cette période, toutes les pièces défectueuses seront remplacées gratuitement, dans la mesure où la défaillance n'est pas due à une mauvaise utilisation, un accident ou une négligence. Toute réparation sous garantie sera effectuée par le fournisseur.

Malgré la description et les spécifications de l'appareil données dans le manuel de l'utilisateur, Techne se réserve le droit d'effectuer les changements nécessaires à l'appareil ou à tout élément qui entre dans sa composition.

Ce manuel a été exclusivement rédigé à l'attention des clients de Techne, et aucun élément de ce guide d'instructions ne peut être utilisé comme garantie, condition ou représentation concernant la description, commercialisation, adaptation aux conditions d'utilisation ou autre des appareils ou leurs composants.

Entretien utilisateur

IMPORTANT : CET APPAREIL NE PEUT ETRE DEMONTE QUE PAR DU PERSONNEL QUALIFIE. LORSQUE LES PANNEAUX AVANT, ARRIERE ET LATERAUX SONT DEMONTES, L'OPERATEUR EST EXPOSE A DES TENSIONS QUI PEUVENT ETRE MORTELLES.

CET APPAREIL NE CONTIENT AUCUN ELEMENT QUI DEMANDE UN ENTRETIEN DE LA PART DE L'UTILISATEUR.

Dans le cas peu probable où votre appareil présente un défaut de fonctionnement auquel il est difficile de remédier, il est alors préférable de contacter votre fournisseur et, le cas échéant, de renvoyer le matériel. Veuillez inclure une description détaillée du problème constaté et retourner l'appareil dans son emballage d'origine. Techne ne sera pas tenu responsable des dommages subis par tout appareil dont l'emballage est inadéquat pour le transport. Pour plus de sûreté, contactez votre fournisseur. Voir le certificat de décontamination livré avec le produit.

1. Nettoyage

Avant de nettoyer l'appareil, assurez-vous TOUJOURS que le câble d'alimentation est déconnecté et laissez la température redescendre en dessous de 50 °C.

Utilisez un chiffon imprégné d'eau savonneuse pour nettoyer l'appareil. Veillez à ne pas introduire d'eau dans l'appareil. N'utilisez pas de produits abrasifs.

2. Coupe-circuit d'excès de température

- En l'absence de puissance de chauffe, vérifiez la prise et le câble d'alimentation puis réglez la commande du coupe-circuit (si votre appareil est doté de ce mécanisme).
- Si la sécurité se déclenche trop souvent, il s'agit d'un problème plus sérieux. Nous vous conseillons dans ce cas de prendre contact avec votre fournisseur pour réparation.

3. Fusibles

La protection de l'appareil est assurée par un ou deux fusibles dont le remplacement ne peut être effectué que par un personnel qualifié.

Si les fusibles sautent sans arrêt, il s'agit d'un problème sérieux. Nous vous conseillons dans ce cas de prendre contact avec votre fournisseur pour réparation.

Einleitung

Bitte lesen Sie diese Bedienungsanleitung komplett bevor Sie dieses Gerät benutzen.

Warnung

HOHE TEMPERATUREN SIND GEFÄHRLICH: sie können dem Bediener ernsthafte Verletzungen zufügen und brennbare Materialien können sich leicht entzünden.

Techne hat bei der Konstruktion dieses Gerätes sehr darauf geachtet, daß der Bediener vor Gefahren geschützt ist. Dennoch sollten Sie auf die folgenden Punkte achten:

- SEIEN SIE VORSICHTIG UND TRAGEN SIE SCHUTZHANDSCHUHE
- Legen Sie heiße Gegenstände NICHT auf oder in die Nähe von leicht brennbaren Materialien; vermeiden Sie Arbeiten in der Nähe von leicht entzündbaren Flüssigkeiten oder Gasen.
- Bringen sie KEINE Flüssigkeiten direkt in Ihr Gerät.
- Benutzen Sie immer den normalen Menschenverstand

Sicherheit des Anwenders

Alle Benutzer von Techne Geräten müssen Zugang zu der entsprechenden Literatur haben, um ihre Sicherheit zu gewähren.

Es ist wichtig, daß diese Geräte nur von entsprechend geschultem Personal betrieben werden, das die in dieser Gebrauchsanweisung enthaltenen Maßnahmen und allgemeine Sicherheitsbestimmungen und -vorkehrungen beachtet. Wenn das Gerät anders eingesetzt wird als vom Hersteller empfohlen, kann dies die persönliche Sicherheit des Anwenders beeinträchtigen. Die Geräte von Techne entsprechen den internationalen Sicherheitsbestimmungen und sind mit einem automatischen Übertemperaturabschalter ausgestattet. Bei einigen Modellen ist der Übertemperaturabschalter verstellbar und sollte je nach Anwendung entsprechend eingestellt werden. Bei allen anderen Modellen ist der Temperaturschutz voreingestellt um Schäden am Gerät zu vermeiden. Wenn ein Sicherheitsproblem auftreten sollte, muß das Gerät ausgeschaltet und vom Stromnetz getrennt werden.

Installation

1. Alle Techne Geräte werden mit einem Stromanschlußkabel geliefert. Dieses ist entweder fest mit dem Gerät verbunden oder zum Einstecken.
2. Vergleichen Sie, ob die Spannung Ihrer Stromversorgung mit den Angaben auf dem Typenschild des Gerätes übereinstimmen. Verbinden Sie das Stromanschlußkabel mit einer geeigneten Stromversorgung gemäß der nächstehenden Tabelle. Achtung: Das Gerät muß geerdet sein, um die elektrische Sicherheit zu gewährleisten!

Verbindungen	220V-240V	110V-120V
Stromführend	Braun	Schwarz
Neutral	Blau	Weiß
Erde	Grün/Gelb	Grün

Geräte, die für 230 Volt ausgelegt sind, können auch bei 220 Volt arbeiten, Geräte für 120 Volt auch bei 110 Volt. In beiden Fällen verringert sich die Aufheizrate um ca. 8%. Das Typenschild befindet sich hinten am Gerät.

3. Stecken Sie das Stromkabel in die vorgesehene Buchse hinten am Gerät.
4. Stellen Sie das Gerät auf eine ebene Arbeitsfläche bzw. (falls erforderlich) unter einen Laborabzug. Beachten Sie, daß die Entlüftungsrippen an der Geräteunterseite immer frei zugänglich sind.
5. Wenn die Anzeigenlämpchen an der Vorderseite leuchten, hat dies folgende Bedeutung:

 : Gerät ist eingeschaltet

 : Gerät heizt

 : Übertemperaturschutz ist ausgelöst

6. Die Symbole auf oder neben dem EIN/AUS-Schalter an der Geräterückseite bedeuten:

I : An

O : Aus

Nach dem Gebrauch

Vergessen Sie nicht, daß Teile des Gerätes (die Gefäße, die Blöcke und andere Zubehörteile) nach dem Erhitzen von Proben noch sehr heiß sein können. Bitte beachten Sie die oben genannten Vorsichtsmaßnahmen.

Garantie

Die Garantiedauer des Gerätes ist auf der beiliegenden Garantiekarte angegeben und schließt Fehler im Material oder der Verarbeitung ein. Die Garantiedauer beginnt am Tag des Einkaufs. Sämtliche defekte Teile werden innerhalb dieses Zeitraumes kostenlos ersetzt unter der Voraussetzung, daß dem Defekt keine unsachgemäße Handhabung, Fahrlässigkeit oder ein Unfall zugrundeliegt. Der unter diese Garantie fallende Service wird vom Lieferanten geleistet.

Ungeachtet der in dieser Gebrauchsanweisung enthaltenen Beschreibungen und Spezifikationen, behält sich Techne hiermit das Recht vor, Änderungen an den Geräten bzw. an einzelnen Geräteteilen durchzuführen.

Diese Gebrauchsanleitung wurde ausschließlich dazu erstellt, um Kunden die Handhabung der Techne-Geräte zu erleichtern. Nichts in dieser Gebrauchsanleitung darf als Garantie, Bedingung oder Voraussetzung verstanden werden, sei es die Beschreibung, Marktgängigkeit, Zweckdienlichkeit oder sonstiges bezüglich der Geräte oder deren Bestandteile.

Wartung durch den Bediener

BEACHTEN SIE, DASS DIESES GERÄT NUR VON TECHNISCHEN FACHKRÄFTEN GEÖFFNET UND DEMONTIERT WERDEN DARF.

DURCH ENTFERNEN DES GERÄUSES ODER GEHÄUSETEILEN SIND BAUTEILE MIT LEBENGEFÄHRLICHEN SPANNUNGEN FREI ZUGÄNGLICH.

IM INNERN DES GERÄTES BEFINDEN SICH KEINE TEILE, DIE VOM ANWENDER GEWARTET WERDEN MÜSSEN.

Falls Ihr Gerät nicht ordnungsgemäß arbeitet, wenden Sie sich an Ihren Lieferanten oder senden Sie das Gerät wenn nötig zurück. Fügen Sie eine genaue Beschreibung des Defektes bei. Verpacken Sie das Gerät möglichst im Originalkarton. Bitte beachten Sie, daß Techne und thermo-DUX keine Haftung bei Transportschäden aufgrund unzureichender Verpackung übernehmen. Setzen Sie sich im Zweifelsfall mit Ihrem Lieferanten in Verbindung. Bitte beachten Sie die Entgiftungsbescheinigung, die Sie mit dem Gerät erhalten haben.

1. Reinigen

Bevor Sie Ihr Gerät reinigen, sollten Sie

- zuerst den Netzstecker ziehen
- das Gerät unter 50°C abkühlen lassen.

Ein feuchtes Tuch mit Seifenlösung reinigt Ihr Gerät am besten. Achten Sie darauf, daß kein Wasser in das Gerät gelangt. Verwenden Sie keine Scheuermittel.

2. Übertemperaturabschalter

- Der Übertemperaturschutz ist ein empfindliches mechanisches Teil. Schon eine Erschütterung kann diesen auslösen.
- Falls die Heizung nicht funktioniert, überprüfen Sie zuerst Netzstecker und Kabel. Setzen Sie dann den Übertemperaturabschalter (an der Rückseite des Gerätes) wieder zurück, indem Sie den roten Knopf einmal bis zum Anschlag drücken.
- Wenn der Übertemperaturabschalter wiederholt auslöst, liegt ein größerer Defekt vor. Das Gerät muß zur Reparatur an Ihren Lieferanten eingeschickt werden.

3. Sicherungen

Die Stromzuleitung ist durch ein oder zwei Sicherungen geschützt. Diese sollten nur durch qualifiziertes Fachpersonal ausgetauscht werden. Wenn die Sicherung wiederholt durchbrennt, liegt ein größerer Defekt vor. Das Gerät muß zur Reparatur an Ihren Lieferanten eingeschickt werden.

Introducción

Le rogamos lea cuidadosamente la información contenida en este folleto antes de manipular el aparato.

Aviso

LAS TEMPERATURAS ELEVADAS SON PELIGROSAS: pueden causarle graves quemaduras y provocar fuego en materiales combustibles.

Techne ha puesto gran cuidado en el diseño de estos aparatos para proteger al usuario de cualquier peligro; aún así se deberá prestar atención a los siguientes puntos:

- EXTREME LAS PRECAUCIONES Y UTILICE GUANTES PARA PROTEGERSE LAS MANOS;
- NO coloque objetos calientes encima o cerca de objetos combustibles;
- NO maneje el aparato cerca de líquidos inflamables o gases;
- NO introduzca ningún líquido directamente en el aparato;
- UTILICE EL SENTIDO COMUN en todo momento.

Seguridad del usuario

Todos los usuarios de equipos Techne deben disponer de la información necesaria para asegurar su seguridad.

De acuerdo con las instrucciones contenidas en este manual y con las normas y procedimientos generales de seguridad, es muy importante que sólo personal debidamente capacitado opere estos aparatos. De no ser así, la protección que el equipo le proporciona al usuario puede verse reducida.

Todos los equipos Techne han sido diseñados para cumplir con los requisitos internacionales de seguridad y traen incorporados un sistema de desconexión en caso de sobretemperatura. En algunos modelos el sistema de desconexión es variable, lo que le permite elegir la temperatura según sus necesidades. En otros, el sistema de desconexión viene ya ajustado para evitar daños en el equipo.

En caso de que surgiera un problema de seguridad, desconecte el equipo de la red.

Instalación

1. Todos los aparatos Techne se suministran con un cable de alimentación. Puede ser fijo o independiente del aparato.
2. Antes de conectarlo, compruebe que el voltaje corresponde al de la placa indicadora. Conecte el cable de alimentación a un enchufe adecuado según la tabla expuesta a continuación. El equipo debe estar conectado a tierra para garantizar la seguridad eléctrica.

<i>Conexiones</i>	220V-240V	110V-120V
Línea	Marrón	Negro
Neutro	Azul	Blanco
Tierra	Verde/amarillo	Verde

Asegúrese de que los equipos marcados 230V en la placa indicadora funcionan a 220V y de que los equipos marcados 120V funcionan a 110V. No obstante, en ambos casos la velocidad de calentamiento se verá reducida en un 8% aproximadamente. La placa indicadora está situada en la parte posterior del equipo.

3. Conecte el cable a la toma de tensión en la parte posterior del equipo.
4. Sitúe el aparato en un lugar apropiado tal como una superficie de trabajo plana, o si fuera necesario incluso en una campana con extractor de humos, asegurándose de que las entradas de aire en la parte inferior no queden obstruidas.
5. Los símbolos, que pueden aparecer junto a las luces indicadoras en el panel frontal del equipo, tienen los siguientes significados:

 : Indicador de potencia

 : Indicador del calor

 : Indicador de sobretemperatura

6. Los símbolos que se encuentran en o cerca del interruptor de alimentación tienen los siguientes significados:

I : Interruptor principal encendido

O : Interruptor principal apagado

Después de su uso

Cuando haya finalizado el calentamiento de muestras, recuerde que las piezas del equipo, tales como tubos, bloques y demás accesorios, pueden estar muy calientes. Tome las precauciones mencionadas anteriormente.

Garantía

Este aparato está garantizado contra cualquier defecto material o de fabricación durante el periodo especificado en la tarjeta de garantía adjunta. Este plazo inicia a partir de la fecha de compra, y dentro de este periodo todas las piezas defectuosas serán reemplazadas gratuitamente siempre que el defecto no sea resultado de un uso incorrecto, accidente o negligencia. Mientras se encuentre bajo garantía las revisiones las debe llevar a cabo el proveedor.

A pesar de la descripción y las especificaciones de los aparatos contenidas en el Manual del Usuario, Techne se reserva por medio de este documento el derecho a efectuar los cambios que estime oportunos tanto en los aparatos como en cualquier componente de los mismos.

Este manual ha sido preparado exclusivamente para los clientes de Techne y nada de lo especificado en este folleto de instrucciones se tomará como una garantía, condición o aseveración de la descripción, comerciabilidad o adecuación para cualquier fin específico de los aparatos o sus componentes.

Mantenimiento

ESTE APARATO DEBE SER DESMONTADO SOLO Y EXCLUSIVAMENTE POR PERSONAL DEBIDAMENTE CAPACITADO.

EL RETIRAR LOS PANELES LATERALES, FRONTALES O TRASEROS SUPONE DEJAR AL DESCUBIERTO TENSION DE LA RED PELIGROSA.

EL EQUIPO NO CONSTA DE NINGUNA PIEZA DE CUYO MANTENIMIENTO SE PUEDA ENCARGAR EL USUARIO.

En el caso improbable de que experimentara algún problema con su aparato que no pudiera resolver con facilidad, debería ponerse en contacto con su proveedor y devolverlo si fuera necesario. Indique de forma detallada todos los defectos que haya notado y devuelva el equipo en su embalaje original. Techne no aceptará responsabilidad alguna por daños causados en equipos que no estuvieran debidamente embalados para su envío; si tuviera alguna duda, póngase en contacto con su proveedor. Sírvese consultar el Certificado de Descontaminación suministrado con su aparato.

1. Limpieza

Antes de limpiar su aparato, desconéctelo SIEMPRE de la fuente de alimentación y permita que se enfríe por debajo de los 50°C.

Este aparato se puede limpiar pasándole un paño húmedo enjabonado. Hágalo con cuidado para evitar que caiga agua dentro del mismo. No utilice limpiadores abrasivos.

2. Desconexión en caso de sobretemperaturas

El sistema de desconexión en caso de sobretemperaturas es un dispositivo mecánico sensible (una sacudida mecánica podría desconectarlo).

- Si el calefactor no recibiera alimentación, compruebe el enchufe y el cable de la toma de corriente; a continuación vuelva a ajustar el control del dispositivo (si su equipo lo lleva montado).
- Una desconexión repetida indicaría una avería grave; puede que tenga que devolverle el aparato a su proveedor para su reparación.

3. Fusibles

Su aparato está protegido por uno o dos fusibles. Sólo deben cambiarlos personal debidamente capacitado.

Si los fusibles se fundieran repetidamente, esto indicaría una avería grave y puede que tuviera que devolverle el aparato a su proveedor para su reparación.

Introduzione

Prima di utilizzare l'apparecchio, leggere tutte le informazioni contenute in questo manuale.

Attenzione

Le alte temperature sono pericolose: possono causare ustioni gravi all'utilizzatore e possono causare la combustione di materiale infiammabile. La Techne ha posto particolare cura nel progettare questo strumento, al fine di proteggere gli operatori da eventuali pericoli, ma gli utilizzatori devono prestare attenzione ai seguenti punti:

- Utilizzare con attenzione e indossare guanti protettivi;
- Non mettere vicini oggetti caldi o oggetti infiammabili;
- Non azionare il riscaldatore Techne vicino a liquidi infiammabili o benzine;
- Non introdurre nessun liquido all'interno dell'unità;
- In ogni caso Usare Buon Senso.

Sicurezza per l'utilizzatore

Il personale che utilizza l'apparecchiatura Techne deve avere a disposizione la documentazione necessaria al fine di assicurare la loro incolumità.

È importante che solo personale adeguatamente addestrato utilizzi questo apparecchio, in conformità alle istruzioni contenute in questo manuale e nel rispetto delle normative e procedure generali di sicurezza.

Se l'apparecchio è utilizzato in modo non specificato da Techne, la protezione fornita dall'apparecchiatura all'utilizzatore potrebbe essere a rischio.

Tutte le unità Techne sono state progettate in conformità ai requisiti internazionali di sicurezza e sono equipaggiate con un interruttore anti surriscaldamento. Su alcuni modelli, l'interruttore è regolabile e dovrebbe essere impostato secondo l'utilizzo. In tutti gli altri modelli l'interruttore è prerogolato per proteggere l'unità.

Se si dovesse verificare qualche problema di sicurezza, disconnettere l'apparecchio dalla rete.

Installazione

1. Tutti gli apparecchi Techne sono forniti di un cavo di alimentazione. Questo può essere integrato nell'apparecchio o separato.

2. Prima di collegare l'apparecchio alla presa di alimentazione, controllare il voltaggio indicato sulla targhetta. La targhetta identificativa si trova sul retro dell'apparecchio. Collegare il cavo di alimentazione in una presa appropriata secondo la tabella seguente.

L'apparecchio deve essere collegato alla messa a terra per assicurare la giusta sicurezza elettrica.

<i>Connessioni</i>	220V-240V	110V-120V
Tensione	MarroneNera	
Neutro	Blu	Bianco
Terra	Verde/Giallo	Verde

Il fusibile all'interno dell'apparecchio protegge l'apparecchiatura e l'utilizzatore.

Tenere presente che gli apparecchi riportanti sulla targhetta 230 V funzionano a 220V. Gli apparecchi riportanti 120V funzionano a 110V. Comunque, in entrambi i casi la velocità di riscaldamento diminuirà approssimativamente dell'8%.

3. Collegare il cavo elettrico alla presa di corrente sul retro dell'unità.
4. Posizionare l'unità su un luogo adeguato, su una superficie di lavoro piana oppure, se necessario, sotto una cappa aspiratrice, assicurandosi che le prese di aria sulla parte inferiore siano libere da ostruzione.
5. I simboli seguenti, che possono essere collocati in prossimità delle luci di indicazione sul pannello anteriore dell'apparecchio, hanno i seguenti significati:

~	indicatore di potenza
⚡	indicatore di riscaldamento
🔥	indicatore di surriscaldamento

6. I simboli sopra o vicino l'interruttore di accensione dell'apparecchio hanno i significati seguenti:

I	Acceso
O	Spento

Dopo l'uso

Quando avrete terminato di riscaldare i campioni, ricordate che le parti dell'apparecchio – le provette, i loro supporti e gli altri accessori – possono essere bollenti. Seguire le precauzioni elencate in precedenza.

Garanzia

L'apparecchio è garantito contro ogni difetto del materiale o fabbricazione per il periodo specificato sul certificato di garanzia accluso. Questo periodo decorre dalla data di acquisto, e durante il quale tutte le parti difettose verranno sostituite gratuitamente purché il difetto non sia causato da un uso non appropriato, da cause non imputabili a difetti di fabbricazione o negligenza. L'assistenza durante questo periodo sarà garantita dal fornitore.

Ferme restando la descrizione e le caratteristiche dell'apparecchio contenute nel Manuale d'uso dell'utilizzatore, la Techne si riserva in ogni caso il diritto di effettuare le modifiche che riterrà necessarie all'apparecchio o ai suoi componenti.

Questo Manuale è stato realizzato esclusivamente a vantaggio dei clienti della Techne e in alcun modo potrà essere utilizzato come garanzia, condizione o rappresentazione concernente la descrizione, commercializzazione, adeguamento alle condizioni di utilizzo o altro degli apparecchi o delle sue componenti.

Manutenzione

Questo apparecchio dovrà essere aperto esclusivamente da Personale adeguatamente addestrato. La rimozione dei pannelli laterali, frontali o posteriori può esporre potenzialmente a voltaggi di corrente letali. All'interno dell'apparecchio non ci sono parti manutenibili da parte dell'utilizzatore.

Nell'eventualità che si riscontrino un problema con l'apparecchio che non può essere facilmente risolto, si dovrà contattare il proprio fornitore e restituire, se necessario, l'apparecchio. Si prega di specificare nel dettaglio i difetti riscontrati e di ricordare di restituire l'apparecchio nel suo involucro originale. La Techne non si fa carico di alcuna responsabilità per danni subiti dall'apparecchio che non sia stato propriamente imballato per il trasporto; in caso di dubbio, rivolgersi al fornitore. Vedere il Certificato di Decontaminazione fornito con il vostro apparecchio.

1. Pulizia

Prima di pulire il vostro apparecchio, disconnettere sempre la presa di alimentazione e lasciare raffreddare sotto i 50° C. Questo apparecchio può essere pulito passando un panno inumidito con sapone. Si deve prestare attenzione onde prevenire l'ingresso dell'acqua all'interno dell'apparecchio. Non utilizzare per la pulizia sostanze abrasive.

2. Disconnessione in caso di surriscaldamento

In caso di non funzionamento dell'apparecchio, controllare la spina elettrica e il relativo cavo collegati alla rete. Ripetute interruzioni del funzionamento dell'apparecchio indicano un serio malfunzionamento: in questo caso restituire l'apparecchio al fornitore per la riparazione.

3. Fusibili

L'apparecchio è protetto da uno o due fusibili. Questi dovrebbero essere sostituiti solo da personale qualificato. Se i fusibili si bruciano frequentemente ciò indica un malfunzionamento serio e in questo caso si consiglia di contattare il fornitore per le riparazioni.

Per informazioni tecniche

Per informazioni tecniche di vendita o sull'assistenza contattare l'agente locale Techne o, direttamente la Techne,

Duxford, CAMBRIDGE, CB2 4PZ, United Kingdom.

Telefono: +44 (0)1223 832401

Telefax: +44 (0)1223 836838

Assistenza: +44 (0)1223 836950

24 ore risposta automatica

e-mail: sales@technc.com

Web site: www.techne.com

THE DRI-BLOCK®

Please read all the information in this manual before using the unit.

Techne's Dri-Block® heaters provide a safe, dry, constant temperature source in the laboratory. You can use the units for incubation, boiling, inactivation, wet ashing, sample concentration, enzyme analysis and many other clinical and industrial purposes.

The units cover the temperature range from 25°C to 200°C using machined aluminium alloy blocks as the heat transfer medium: temperature control circuits are built into the unit. Independent indicator lights indicate mains power, heater action and overtemperature cut-out. An ON/OFF switch is mounted on the rear panel, together with the mains connector and a double fuse holder.

The units are constructed in PPS plastic, which is strong yet lightweight and can resist sustained temperatures as high as 260°C. Even though the units heat up rapidly, highly efficient insulation ensures that cases remain cool enough to handle even at maximum operating temperatures.

Techne's Dri-Block® range has been designed to comply with all relevant RF (Radio Frequency) interference and electrical safety regulations.

The operating instructions in this Operator's Manual covers three of a range of Dri-Blocks®:

- DB-1M
- DB-2A
- DB-2P

The features of individual models are outlined in the 'Specification' section of this manual.

Other units covered in other manuals are:

- DB-3
- DB-3A
- DB-2D
- DB-3D

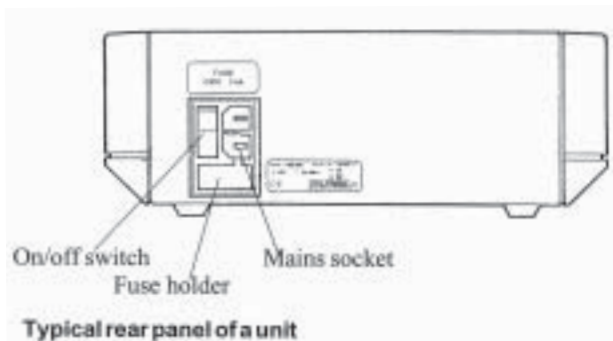

Unpacking

When unpacking the unit, check that the following have been removed from the packing: The unit; a Guarantee card; a De-contamination Certificate.

Within the guarantee period, shown on the Guarantee Card, we undertake to supply replacements free of charge for parts which may on examination prove to be defective, provided that the defect is not the result of misuse, accident or negligence. Any instrument requiring service under this guarantee should be sent to the supplier through whom it was purchased, or, in the case of difficulty, it should be carefully packed in its original packing and consigned, carriage paid, to us. Techne takes no responsibility for returned goods damaged in transit.

Returned goods will not be processed without a Returns Authorisation Number. Call + (44) (0)1223 832401 for a number. On all correspondence, please quote the Serial Number in full and/or the Sales Order Number. Please write the Returns Number on the outside of any packing.

Working Environment (all units)

The Dri-Block® units are designed to work safely under the following conditions:

Ambient temp. range 5°C to 40°C

Humidity Up to 95% relative humidity, non-condensing

Note: The control specifications are quoted for an ambient temperature of 20°C for units fitted with 2 or 3 insert blocks type F3506, or an F4467 in the case of the DB-1M. The specification will be closely held if the ambient temperature is in the range 10°C to 30°C. Outside this range the quoted figures may deteriorate but the unit will still work safely.

Radio frequency interference tested and passed to EN50081-1.

Immunity Tested and passed to EN50082-1

SPECIFICATION

The DB-1M Dri-Block®

This unit has a recessed chamber to hold interchangeable blocks. The blocks are machined to accept various microplates, one of which is the Techne HI-TEMP 96™ microplate. Temperature control is provided by three adjustable presets on the front panel. The DB-1M has a cover to hold the plates in optimum thermal contact with the block.

The DB-1M is supplied with a screw driver for adjusting the pre-sets and a plastic lid which clips onto the hinge on the unit.

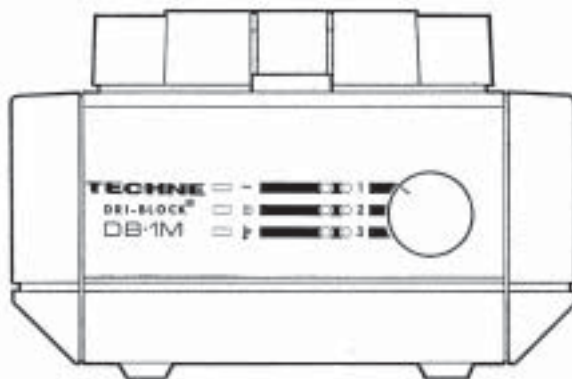

Temperature range	25°C to 105°C
Temperature stability	±0.1°C at 40°C
Temperature setting	3 adjustable presets
Max. temperature variation	0.2°C at 40° C
Heat up time 30° C to 37° C	15 minutes
Heat up time 30° C to 56° C	27 minutes
Heat up time 30° C to 100° C	30 minutes
Number of blocks	1 Multiwell

Electrical supply

<i>Voltage</i>	<i>Cycles</i>	<i>Power</i>
220V-240V	50Hz-60Hz	400W
110V-120V	50Hz-60Hz	400W

The DB-2P Dri-Block®

This unit has a recessed chamber to hold one or two interchangeable insert blocks which accept test tubes or other sample containers. Temperature is set by three adjustable presets on the front panel.

The DB-2P is supplied with a screw driver for adjusting the pre-sets, an extraction tool for removing the insert blocks from the unit and two plastic half blocks for reducing heat losses when only one aluminium block is used.

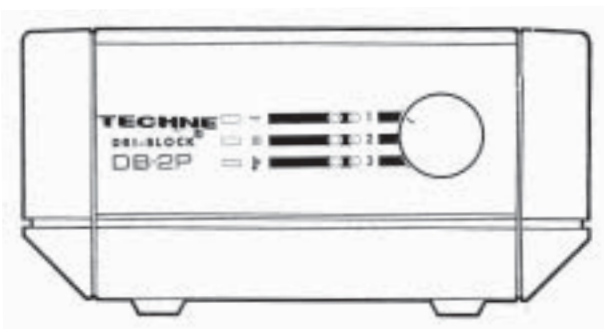

Temperature range	25°C to 105°C
Temperature stability	±0.1°C at 40°C
Temperature setting	3 adjustable presets
Max temperature variation between blocks	0.2°C at 40° C
Heat up time 30° C to 37° C	9 minutes
Heat up time 30° C to 56° C	10 minutes
Heat up time 30°C to 100°C	15 minutes
Number of blocks	2

Electrical supply

<i>Voltage</i>	<i>Cycles</i>	<i>Power</i>
220V-240V	50Hz-60Hz	400W
110V-120V	50Hz-60Hz	400W

The DB-2A Dri-Block®

This unit has a recessed chamber which can hold one or two interchangeable insert blocks which accept test tubes or other sample containers. Temperature is set by a front panel dial marked in degrees Celsius.

The DB-2A is supplied with an extraction tool for removing the insert blocks from the unit and two plastic half blocks for reducing heat losses when only one aluminium block is used.

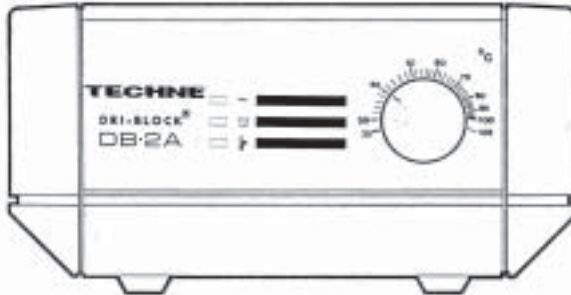

Temperature range	25°C to 100°C
Temperature stability	±0.1°C at 40°C
Temperature setting	Rotary knob
Temperature scale graduation	2°C
Set point accuracy	±2°C
Max temperature variation between blocks	0.2°C at 40° C
Heat up time 30° C to 37° C	8 minutes
Heat up time 30° C to 56° C	9 minutes
Heat up time 30°C to 100°C	12 minutes
Number of blocks	2

Electrical supply

<i>Voltage</i>	<i>Cycles</i>	<i>Power</i>
220V-240V	50Hz-60Hz	400W
110V-120V	50Hz-60Hz	400W

OPERATION

Preparation

1. Select the insert block(s) appropriate to the application. A list of available blocks is given on page 21 of this manual. Ensure that both the underside of the block(s) and the top of the hotplate are clean; efficient heat conduction between these two surfaces is essential.

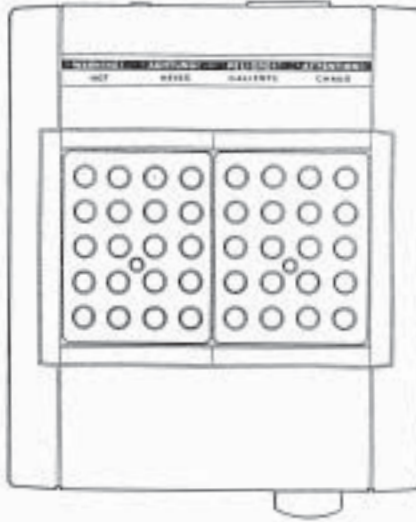

Top view of model DB-2P, showing two insert blocks

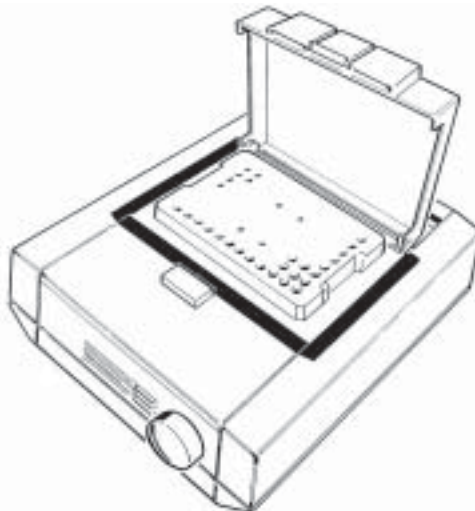

The DB-1M with a block for Hi-Temp 96 microplates

2. Place the aluminium alloy insert blocks into the well of the unit and place the tubes containing the sample liquid in the blocks.
3. The DB-1M takes a single block for Techne HI-TEMP 96™ microplates. This unit can take other blocks for other makes of plate, but you must ensure that the plates can withstand the maximum temperature of the protocol. (note that the lid is closed during use to improve thermal contact)
4. The heater design, temperature sensor and control circuit give good temperature control and uniformity, but make sure that there is a close fit of the tubes in the block to allow efficient heat transfer.
5. If less than the maximum number of insert blocks are fitted it is recommended that you fit plastic half blocks to the space either side of the aluminium block. A pair of Plastic half blocks are supplied with the DB-2A, DB-2D and the DB-2P. The dummy blocks have the effect of reducing heat losses, thus improving temperature stability.

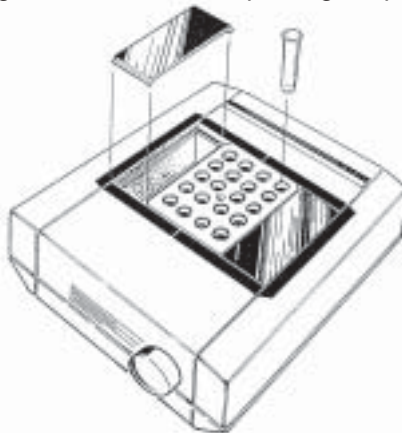

The DB-2A showing the use of plastic half blocks

6. Plug the mains cable into the socket in the rear of the unit. Connect to the mains electricity supply with the plug provided or one wired correctly for your supply. Switch the power ON from the switch located next to the mains input lead. The mains indicator on the front panel will light (as well as the fuse neon on the mains input unit).

The Overtemperature Cut-out

In the event of a fault occurring which could cause the heater to remain on, power is removed from the heater when the block temperature reaches approximately 110°C.

Setting the Pre-set Temperature

As supplied, all units have presets set to a minimum temperature. In every case, the presets must be set before use.

DB-1M and DB-2P only

To set the presets, follow this procedure:

- Select the preset (1, 2 or 3) to be adjusted with the selector knob
- Place the sample tubes in the block
- Place a thermometer in the sample liquid contained in the tube or directly in the thermometer hole in the block
- Lift and turn the captive plastic cover from the preset to be adjusted, as illustrated below:

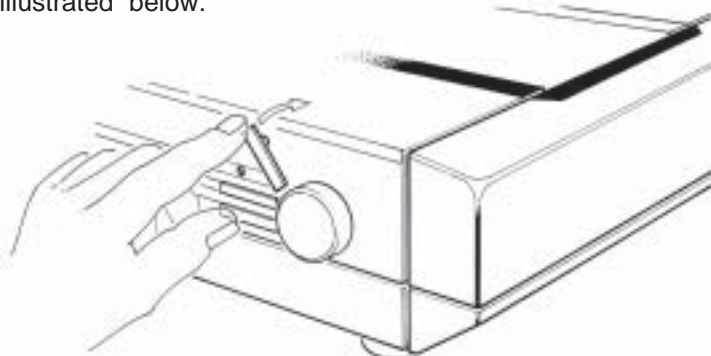

Preset Location

- Insert the screwdriver as supplied into the hole revealed by removing the plastic cover
- Turn the screwdriver clockwise to increase the preset temperature, or anti-clockwise to decrease the preset temperature.

A guide to the number of turns required to attain a particular temperature is given by the graph on page 20. Note that, for units up to Serial N°/4, the temperature range corresponds to approximately 25 complete turns of the potentiometer. For units with Serial N°/5 on, the temperature range corresponds to approximately 4 complete turns of the potentiometer.

- If the setting required is lower than the current setting, use the graph to estimate the number of turns required to reach 10°C *below* the target temperature.
- Allow the temperature of the unit to stabilise after each adjustment.

Remember that the unit heats up quicker than it cools down since the unit is well insulated and heat losses are small. Temperature stabilisation can take approximately thirty to forty minutes for each adjustment.

- Use the graph to estimate the number of turns required to increase the temperature half way to the required temperature.

For example:	up to Ser N°/4	Ser N°/5 on
Current temperature	45°C	45°C
Required temperature	68°C	68°C
From graph number of turn	9	1.2
Turn the preset (turns)	4 1/2	0.6

- Measure the temperature when it stabilises and repeat the step above until the required temperature is attained.

When the required temperature is achieved with sufficient accuracy, replace the cover and make a note of the temperature at which the preset is now set.

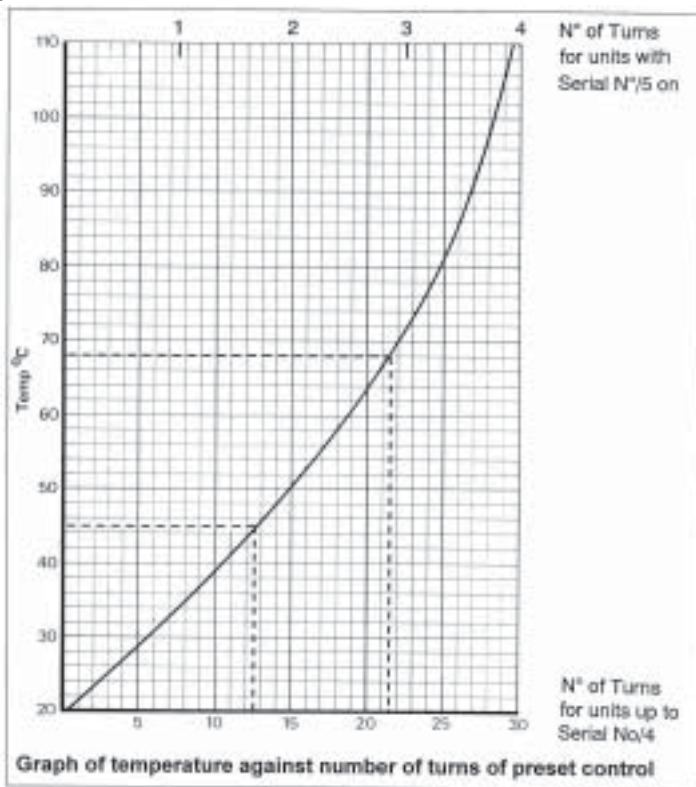

1. DB-1M and DB-2P

Select the preset temperature required (1, 2 or 3) with the selector knob. Setting the temperatures on these presets is described on pages 19-20 of this manual.

DB-2A

Turn the temperature control knob to the required temperature. Note that the actual temperature of the block critically depends on the type of block used and the quality of the thermal contact between the base of the block and the unit.

2. The heater (and heater indicator) comes on if the set temperature is higher than the current block temperature.
3. When the set temperature is approached, the heater indicator will begin to flash and when the temperature is stabilised the indicator will flash slowly.
4. Due to variations in heat losses with different designs of insert block, the actual temperature may vary. The units are calibrated using model F3506 insert blocks (or an F4467 in the case of the DB-1M). Running a DB-2A, a DB-2D or a DB-2P with only one insert block and without the plastic half blocks will reduce the maximum achievable temperature by a few degrees.

If you need to control the temperature to a greater accuracy than the instrument's set point, place a thermometer in the special hole in one of the blocks. For greater accuracy still, you can place the thermometer in the sample liquid in one of the test tubes. In either of these cases, it may be necessary to readjust the temperature control knob or preset adjustment to achieve the precise temperature required. Allow the temperature of the unit to stabilise after each adjustment.

5. There will be a time lag between the heater platten and the insert block achieving the set temperature due to thermal contact between them. Guide times are as shown in the Specifications on pages 12 to 14.

After Use

1. When you have finished heating samples, remember that parts of the unit – the tubes, blocks and associated accessories – may be very hot. Take the precautions listed earlier. We recommend that the blocks should be allowed to cool to 70°C before being removed from the Dri-Block®. They will still have to be handled with care
2. If you need to remove an insert block while it is hot, screw the extractor tool into the thermometer hole and lift the block out vertically. Never leave the extractor tool in the block while it is being used in the Dri-Block®.



Removing an insert block with the extractor tool

ADDITIONAL INFORMATION**Insert Blocks**

Insert blocks are made of aluminium alloy and must be ordered separately from the heater units. The following blocks are available from Techne:

<i>Part</i>	<i>Tube Size</i>	<i>Number of Holes</i>	<i>Size</i>
F3501	Plain block	None	95 x 76 x 51
F3502	6mm	30	95 x 76 x 51
F3503	10mm	20	95 x 76 x 51
F3504	12mm	20	95 x 76 x 51
F3505	13mm	20	95 x 76 x 51
F3506	15mm	12	95 x 76 x 51
F3507	16mm	12	95 x 76 x 51
F3508	19mm	8	95 x 76 x 51
F3509	25mm	6	95 x 76 x 51
F3510	10mm cuvettes	2 channels	95 x 76 x 51
F4460	Plain block	Thermometer hole only	95 x 76 x 51
F4461	9mm/7mm	10/20	95 x 76 x 51
F4462	24mm	6	95 x 76 x 51
F4463	26mm	6	95 x 76 x 51
F4464	1.5ml Eppendorf	20	95 x 76 x 51
F4465	0.5ml Eppendorf	30	95 x 76 x 51
F4466	Plastic half block	Plain	95 x 37 x 50
F4467#	HI-TEMP 96™	96 well	95 x 151 x 50
F4468#	Falcon 96 round btm.	96 well	95 x 151 x 50
F4469#	Falcon 96 flat btm.	96 well	95 x 151 x 50
F4470	2 ml Eppendorf	20	95 x 76 x 51
F4471	0.2ml	72	95 x 76 x 51
F4473#	Titertgene	96	95 x 150 x 61
F4474#	Porvair	96	95 x 150 x 48

DB-1M only

Operator Maintenance

NOTE THAT THIS EQUIPMENT SHOULD ONLY BE DISMANTLED BY PROPERLY TRAINED PERSONNEL. **REMOVING THE SIDE, FRONT OR REAR PANELS EXPOSES POTENTIALLY LETHAL MAINS VOLTAGES.** THERE ARE NO OPERATOR MAINTAINABLE PARTS WITHIN THE EQUIPMENT.

In the unlikely event that you experience any problems with your Dri-Block[®] which cannot easily be remedied, you should contact your supplier and return the unit if necessary. Please include any details of the fault observed and remember to return the unit in its original packing. Techne accept no responsibility for damage to units which are not properly packed for shipping: if in doubt, contact your supplier.

1. Cleaning

Before cleaning your unit ALWAYS disconnect from the power supply and allow to cool below 50° C. Your Dri-Block[®] can be cleaned by wiping with a damp soapy cloth. Care should be exercised to prevent water from running inside the unit. Do not use abrasive cleaners.

Before using any cleaning or decontamination method except those recommended here, the responsible body or operator should check with Techne that the proposed method will not damage the equipment.

2. Fuses

Your unit is protected by two fuses. These should only be changed by suitably qualified personnel. If the fuses blow persistently, a serious fault is indicated and you may need to return the unit to your supplier for repair.

DB-1M	230V	2 x F2A;	120/100V	2 x F4A
DB-2A	230V	2 x F2A;	120/100V	2 x F4A
DB-2P	230V	2 x F2A	120/100V	2 x F4A

Replacement Parts

The following parts may be obtained from your Techne dealer:

<i>Part Number</i>	<i>Description</i>
6101308	Extraction tool
FCABLEUK	Mains cable with 13amp UK plug (5 amp fuse)
FCABLEEU	Mains cable with R/A Schuko plug
FCABLEUS	Mains cable with 3 pin US plug
FMW11	Techne HI-TEMP 96™ well plate, pack of 25
FMW12	HI-TEMP 96™ well cover, pack of 50
F4466	Plastic half block
6101325	Screw Driver for Presets

