

**GENOVA MK3
LIFE SCIENCE ANALYSER
OPERATING MANUAL**

SAFETY

Please read this information carefully prior to installing or using this equipment.

1. The unit described in this manual is designed to be operated only by trained personnel. Any adjustments, maintenance or repair must be carried out as defined in this manual, by a person qualified to be aware of the hazards involved.
2. It is essential that both operating and service personnel employ a safe system of work, in addition to the detailed instructions specified in this manual.
3. The covers of the unit should only be removed by personnel who have been trained to avoid the risk of shock.
4. References should always be made to the Health & Safety data supplied with any chemicals used. Generally accepted laboratory procedures for the safe handling of chemicals should be employed.
5. If it is suspected that safety protection has been impaired in any way, the unit must be made inoperative and secured against any intended operation. The fault condition should immediately be reported to the appropriate servicing authority.

**GENOVA
LIFE SCIENCE ANALYSER
OPERATING MANUAL**

CONTENTS

SECTION 1	INTRODUCTION	
	Instrument Description	1.1
	Instrument Specifications	1.2
SECTION 2	INSTALLATION	
	Unpacking	2.1
	Installation	2.2
	Controls	2.3
	Inputs/Outputs	2.4
SECTION 3	OPERATION	
	General Principles	3.1
	Power On Self Test	3.2
	Keypad Operation	3.3
	Global Setup Parameters	3.4
	Photometrics Mode	3.5
	Protein Mode	3.6
	Direct UV	3.7
	DNA/RNA Mode	3.8
	Good Practice Guidelines	3.9
SECTION 4	MAINTENANCE	
	General	4.1
	Light Source Replacement	4.2
SECTION 5	OPTIONAL ACCESSORIES	
	Optional Accessories	5.1
	Spares	5.2
SECTION 6	INTERFACING	
	Serial Interface	6.1
	RS232 Output	6.2
	Recorder Output	6.3
	EC Declaration of Conformity	

SECTION 1

INTRODUCTION

1.1 INSTRUMENT DESCRIPTION

The Genova UV/Visible spectrophotometer is optimised for use by the life science research chemist for the routine purity testing of proteins, DNA and bacterial samples. Fully menu driven operation allows ease of use without the need for detailed knowledge of spectroscopy and makes the product ideal for use in teaching laboratories.

Features include dedicated operating modes for DNA/RNA oligonucleotide and protein analysis. Includes DNA programs, auto ratio and direct calculation of ssDNA, dsDNA, RNA and oligonucleotide concentrations and protein calculations including Lowry, Bradford, BCA and direct reading with display of calibration curve. Scanning capability for peak purity check.

1.2 INSTRUMENT SPECIFICATIONS

Transmittance

Range:	0 to 199.9%
Resolution:	0.1%
Stray light	<0.5% @ 340nm and 220nm
Photometric accuracy:	±1%

Absorbance

Range:	-0.300 to 1.999A
Resolution:	0.001A
Photometric stability:	<0.002A Hr after 30 minute warm up
Photometric noise:	<0.001A @ 0A @ 400nm

Concentration

Range:	-300 to 9999
Resolution:	1, 0.1, 0.01 or 0.001
Units:	ppm, mg/l, g/l, M, %, µg/l, µg/ml, mg/ml, ng/ml or blank (mode specific)

Wavelength

Range:	198 to 1000nm
Resolution:	1nm
Accuracy:	±2nm
Repeatability:	±0.5nm
Bandwidth:	5nm typical @ 270nm (8nm over full wavelength range)

Factor:	0 to 199.9, 1000 to 9999
Readout:	Custom LCD Graphics
Outputs:	Analogue (0 to 1.999V d.c.) / RS232 serial port
Light source:	Xenon flash lamp module
Operating Temperature:	5°C to 40°C
Maximum RH:	80%
Input voltage:	115/230V a.c. -20% +10% 50/60Hz
Input power:	<50W
Size:	365(w)x272(d)x160(h) mm
Weight:	6kg

SECTION 2

INSTALLATION

2.1 UNPACKING

Remove the Genova from the packaging and ensure the following items are present:

1. Genova Life Science Analyser
2. Mains cable
3. Pack 8 (300µl) disposable plastic cuvettes (035 132)
4. Instruction manual
5. Optional accessories (as ordered)

2.2 INSTALLATION

MAINS SUPPLY

The Genova is designed to operate on 115/230V a.c. supplies (-20% +10%) 50/60Hz.

The standard 2 metre mains cable supplied with the unit is fitted with an IEC type connector which can be plugged directly into the POWER IN socket on the rear panel.

The mains fuse is housed within the POWER IN socket. When replacing the fuse the unit should be disconnected from the mains supply.

In the event of the fuse failing after replacement it is advisable to consult with the manufacturer or your local dealer before proceeding further.

Fuse rating: 2A 'F' (fast blow type)

NOTE: The unit should be positioned within 1.5 metres of an earthed mains supply.

VOLTAGE SELECT

NOTE: When changing the voltage select switch position always ensure the fuse rating is correct.

Before attempting to change the voltage select disconnect the unit from the mains supply. withdraw the fuse holder from the power input socket and remove the fuse. Extract the grey fuse retainer and rotate so that the correct voltage is visible through the aperture in the fuse holder. Replace the fuse retainer in its holder, fit the correct fuse and push assembly back into the power input socket.

MAINS CONNECTIONS

A suitable plug should be connected to the 3 wires on the mains lead. These are colour coded to conform with the internationally recognised standard such that:

BROWN	LIVE
BLUE	NEUTRAL
GREEN/YELLOW	EARTH

IMPORTANT – THE UNIT MUST BE EARTHED.

The Green/Yellow wire in the a.c.supply cable must be connected to a properly grounded terminal

2.3 CONTROLS

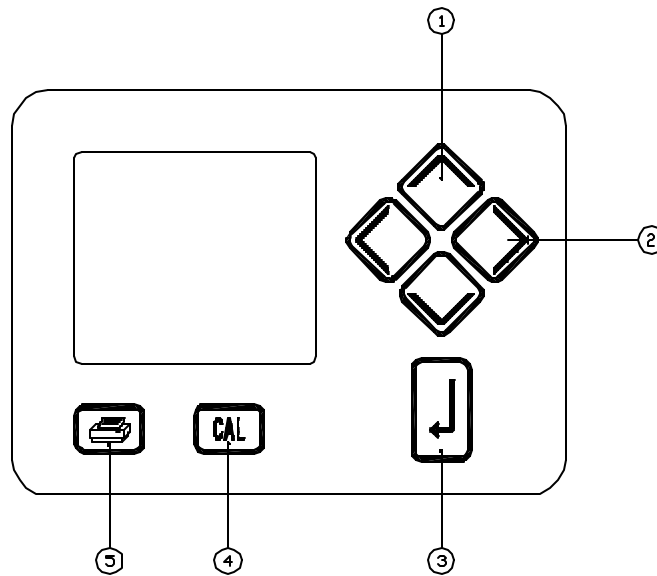

1. **UP/DOWN KEYS** used to move the highlight around menu/screen options unless editing a parameter. In this instance these keys are used to adjust the highlighted parameter.
2. **LEFT/RIGHT KEYS** used to move the highlight around menu/screen options. If editing a numeric value the highlighted digit can be altered. If the highlight is moved off the left most digit the data editing will be aborted and the previous value will be re-instated.
3. **ENTER KEY** used to select the highlighted menu option or to store the current parameter being entered.
4. **CAL KEY** initiates a calibration routine (absorbance zero).
5. **PRINT KEY** provides a printout of the current reading with an incremental sample number. When pressed for the first time after a calibration, the print out will give calibration information. The incremental sample number will be reset after a calibration.

2.4 INPUTS/OUTPUTS

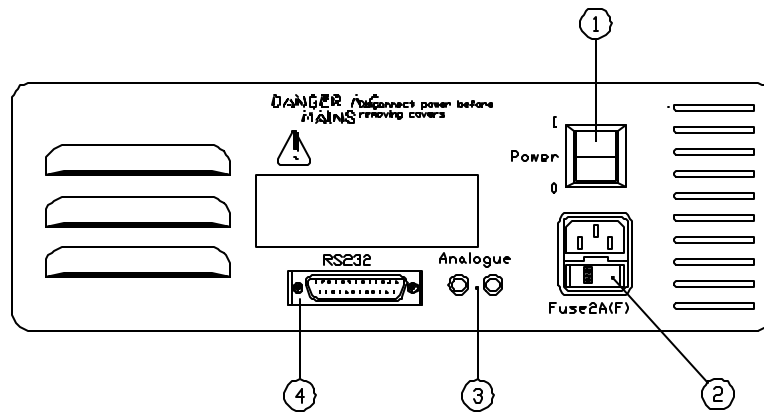

- | | |
|---------------------------|--|
| 1. ROCKER SWITCH | On/off switch for the unit |
| 2. POWER IN SOCKET | IEC type connection socket for mains cable |
| 3. OUTPUT SOCKETS | Analogue output |
| 4. OUTPUT SOCKET | Output socket for (25 way) for RS232 |

SECTION 3

OPERATION

3.1 GENERAL PRINCIPLES

The Genova is a grating spectrophotometer with a selectable wavelength range of 198 – 1000nm. For specific nucleotide and protein assays software is on-board to facilitate rapid analysis of these compounds.

Using spectroscopy, the quantitative analysis of these assays has now become a routine method in many laboratories. It includes absorption measurement, primarily in the ultraviolet range. Proteins are measured directly at 280nm, nucleic acids at 260nm and colorimetric protein determination is carried out within the range of 550 to 600nm.

Nucleic Acid Determination

DNA, RNA and oligonucleotides can be measured directly in aqueous solutions in a diluted or undiluted form. Aqueous buffers with low ion concentrations (e.g. TE buffer) are ideal for this method. The concentration is determined by measuring at 260nm against a blank and then evaluating against factor.

The absorption of 1 OD (A) is equivalent to, approximately:
50µg/ml dsDNA, 37µg/ml ssDNA, 40µg/ml RNA or 30µg/ml for oligonucleotides.

Purity determination of DNA interference by contaminants can be recognised by the calculation of ratio. The ratio A_{260}/A_{280} is used to estimate the purity of nucleic acid, since proteins absorb at 280nm.

Pure DNA should have a ratio of approximately 1.8; pure RNA 2.0. Absorption at 230nm reflects contamination of the sample by substances such as peptides, phenols, aromatic compounds or carbohydrates. In pure samples the ratio should be approximately 2.2.

Referring to a blank value where no absorption should occur is commonly required. On the Genova this default reference is 320nm. Should you then wish to change or modify these wavelengths, this flexibility is in-built.

Protein Determination

Several analytical procedures can be used to determine the protein content of a preparation. Evaluation can be carried out either via a calibration curve or a factor using up to 6 standards.

The Genova uses the following methods of analysis:

B.C.A. (second order curve fit; quadratic)	562nm
Bradford (second order curve fit; quadratic)	590 or 595nm
Lowry (second order curve fit; quadratic)	550/750nm or 500/750nm
Biuret (first order curve fit; quadratic)	540 or 550nm
Direct UV (multi-wavelength)	

B.C.A. – (Bicinchoninine acid assay)

This test is a highly regarded alternative to the Lowry assay, being much easier to carry out and sensitivity can be varied using different temperatures. The dye complex is very stable. This test, however, can be susceptible to interference, but its insensitivity to detergents is comparable to the Lowry method.

Bradford assay

This method is twice as sensitive as the B.C.A. or Lowry test and is the most sensitive quantitative dye assay. It is the easiest to handle and the most rapid method. It also has the additional advantage that a series of reducing substances (e.g. DTT and mercaptoethanol) have no adverse effect on results. It is, however, sensitive to detergents. The main disadvantage with this method is that identical amounts of different standard proteins can cause considerable differences in the resulting absorption coefficients.

Biuret assay

The principle of the Biuret is similar to that of the Lowry. However, it involves a single incubation of 20 minutes. There are very few interfering agents (ammonium salts being one such agent). The Biuret consumes more material. This assay is a good general protein assay for batches of material for which yield is not a problem.

Lowry assay

The principal target is to reduce the high susceptibility to interference. In comparison to the Biuret assay, the sensitivity of this assay has greatly increased. The Lowry method, however, is adversely affected by a wide range of non-proteins. Additives such as EDTA, ammonia sulphate or Triton X-100 in particular are incompatible with the test.

3.2 POWER ON SELF TEST

Prior to switching the unit on check that the voltage select switch is set to the voltage supply being used. When the unit is switched on a self test routine will automatically be performed.

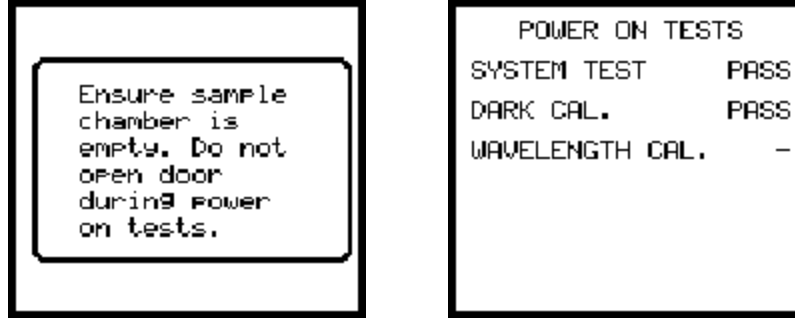

SYSTEM TEST

This test checks the validity of the operating parameters. The following messages may be displayed during this test.

“CRITICAL ERROR – CALIBRATION DATA FAILURE.”

This error is non-recoverable and means the calibration data for the detector is not working and therefore the unit cannot operate. If this message is displayed during the test the manufacturer or local distributor should be contacted immediately for advice.

“SYSTEM ERROR – OPERATING PARAMETERS FAILURE”

This error is recoverable and means that the setup and operating parameters have been reset to their default values, possibly due to memory corruption. To continue press any key.

DARK CALIBRATION TEST

The message “SYSTEM ERROR – DARK LEVEL CALIBRATION FAILURE” may be displayed if the unit receives too much light when trying to perform a dark level calibration. Pressing any key clears this message and the unit will retry calibration. It will repeat this process until it passes the test satisfactorily.

WAVELENGTH CALIBRATION

This part of the self test checks the optical alignment of the unit.

If it fails this test an error message “SYSTEM ERROR – WAVELENGTH CALIBRATION FAILURE” will be displayed. This message is displayed permanently on screen and can only be removed by powering the unit off. If this message is displayed during the test the manufacturer or local distributor should be contacted immediately for advice.

Once the power on self test is successfully completed the main menu will be displayed:

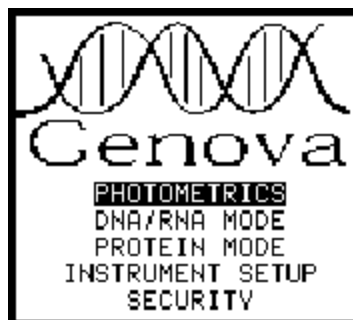

3.3 KEYPAD OPERATION

The following information applies to all setup and operating modes:

- UP/DOWN KEYS** used to move the highlight around menu/screen options unless editing a parameter. In this instance these keys are used to adjust the highlighted parameter.
- LEFT/RIGHT KEYS** used to move the highlight around menu/screen options. If editing a numeric value the highlighted digit can be altered. If the highlight is moved off the left most digit the data editing will be aborted and the previous value will be re-instated.
- ENTER KEY** used to select the highlighted menu option or to store the current parameter being entered.
- CAL KEY** initiates a calibration routine.
- PRINT KEY** provides a printout of the current reading with an incremental sample number. When pressed for the first time after a calibration, the print out will give calibration information. The incremental sample number will be reset after a calibration.

3.4 GLOBAL SETUP PARAMETERS

INSTRUMENT SETUP MENU

This option will allow all instrument related setup (i.e. non-mode specific) parameters to be set up. The options available through the Instrument Setup menu are as follows:

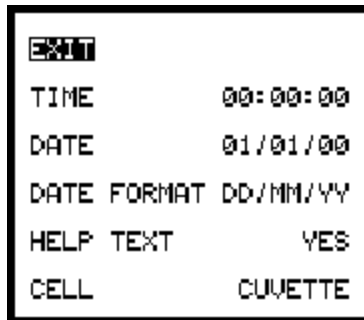

- EXIT** Returns to the main menu screen
- TIME** Allows the user to set the current time into the instrument in the form of HH:MM:SS
- DATE** Allows the user to set the current date into the instrument in the form of either DD:MM:YY or MM:DD:YY depending on the setting of the date format field.
- DATE FORMAT** Allows the user to choose between either the DD:MM:YY formatting of dates or MM:DD:YY formatting. The selected format is applicable to all displayed dates.
- HELP TEXT** Additional help messages will be displayed if the YES option is selected. These messages provide assistance with general operation. If the message does not appear a second time it is because it has already been shown since power on.
- CELL** Allows choice of capillary or cuvette. On selection this will automatically correct the ABS value for the appropriate path length to its displayed value per cm.

SECURITY

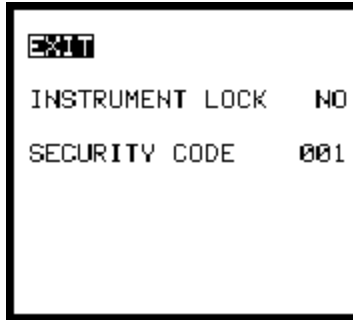

EXIT INSTRUMENT LOCK

Returns to the main menu screen
Yes or no option.

When set to Yes the up and down arrow keys are disabled within set up screens thus preventing operating parameters of the unit from being changed. Standard curve and absorbance zero calibrations are possible when the instrument lock is activated. The Photometrics mode is not affected by the instrument lock feature. When the instrument lock is active, entry of a locking code (0 to 999, set when the instrument lock is activated), is required to re-enter the security option.



SECURITY CODE

Needed to get back into security menu to turn it off. 0-999. If no security number is available turn the unit off and then on holding down the enter key. This then resets to no security code and also any other previously set parameters. Will prompt first message referring to operating parameters indicated by a failure in System Test.

3.5 PHOTOMETRICS MODE

NOTE: Absorbance, %T and Concentration values are displayed simultaneously, i.e. they are not individually selectable.

Having selected **PHOTOMETRICS** from the main menu the following display will be shown:

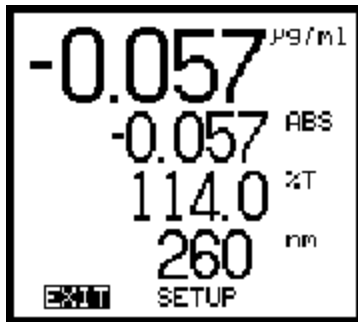

It is recommended that setup parameters be reviewed prior to calibration or measurement to ensure the selected values are correct.

Select **SETUP** and the following options will be displayed:

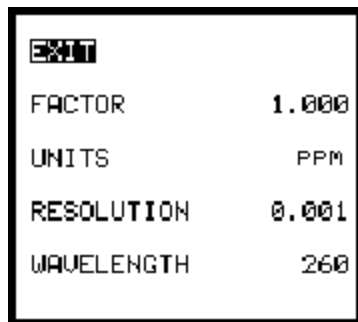

- EXIT** Allows the user to exit this menu
- FACTOR** Used for the concentration calculation where concentration = Factor x Abs
- UNITS** Allows selection of the units used to display against the concentration reading. The choice available: %, M, g/l, mg/l, ppm, none, g/dl
- RESOLUTION** Allows the user to specify the resolution of the displayed reading (1, 0.1, 0.01, 0.001). The maximum resolution that concentration readings are displayed to can be set up to 3 decimal places. The instrument will automatically display concentration readings to the maximum possible resolution using this parameter.
- WAVELENGTH** Allows user setting of preferred wavelength for the test being performed.

Performing a measurement

To perform a measurement it is necessary to set the unit to the required wavelength and perform a calibration.

Place a blank solution into the sample chamber and close the lid. Press the **CAL** key.

The instrument will momentarily show **CAL** indicating that the calibration is being performed.

Once calibrated, the display values will update to show ABS, %T and Concentration readings.

Remove the blank solution from the sample chamber.

The instrument is now ready to perform a measurement. The instrument will now continually perform a live measurement.

The sample value will be shown directly as ABS, %T and Concentration.

3.6 PROTEIN MODE

Select **PROTEIN MODE** from the main menu options.

The following display will be shown:

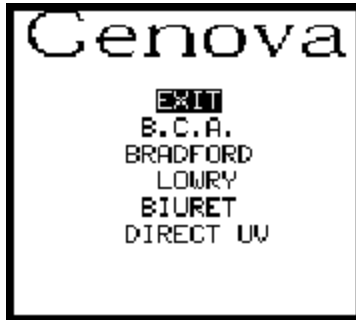

NOTE: B.C.A., Bradford, Lowry and Biuret, although using different wavelength settings, are all performed using the same procedures as detailed below.
Measurement method is by Standard Curve (i.e. absorbance versus concentration).
Curve fit - Quadratic

Select **SETUP** and the following display will be shown:

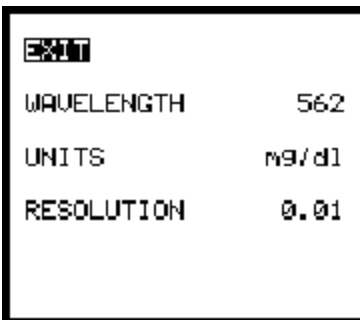

EXIT Allows the user to exit this menu

WAVELENGTH Allows the user to select the appropriate wavelength if different from the standard default values of:

B.C.A.	562nm
Bradford	590nm
Lowry	750nm
Biuret	540nm

UNITS Allows the user to select the preferred measurement unit ($\mu\text{g/ml}$, mg/ml , ng/ml , none, g/dl , mg/dl).

RESOLUTION Allows the user to select the preferred resolution (1, 0.1, 0.01 or 0.001).

The final figure shown will be reduced in resolution if it not possible to show all the required decimal places on the screen.

Prior to sample measurement it is necessary to construct a curve using a number of standards. Select **CURVE** and the following display will be shown:

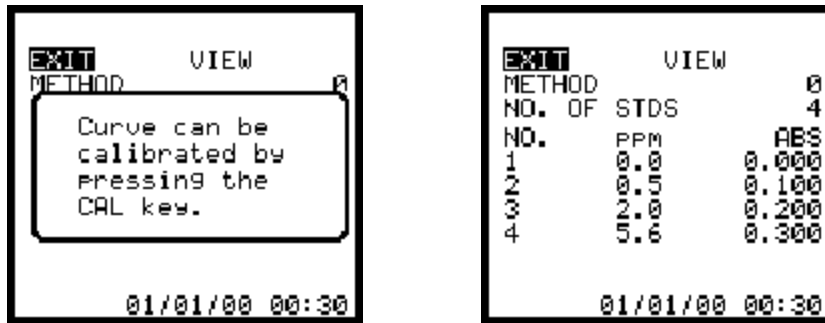

- EXIT** Allows the user to exit this menu
- VIEW** Allows the user to view the calibration curve as a graphic
- METHOD** Allows the user to select which of the 10 methods available they are working on (numbered 0-9). When the method number is changed the data previously displayed is stored against the previous number, and you are presented with the data stored against the current method number
- NO. OF STDS** Number of standards being used for the calibration curve
- NO. ppm ABS** Column headings for the calibration points

NOTE: Date and time will be shown at the bottom of the display. This indicates the last time the method was modified.

Measurements will be displayed in Absorbance only. Enter the values of the standards being used with the lowest concentration value being entered first (lowest to highest value) in the centre column having first selected the unit of measurement required. A minimum of 3 standards to a maximum of 6 is required. Standard curve absorbance values can be manually entered, if known, by the user, or by calibration with known standard solutions.

Press the **CAL** key and the following message will be displayed:



Press the **CAL** key again with a sample blank present in the sample chamber. The display will momentarily show **CAL**.

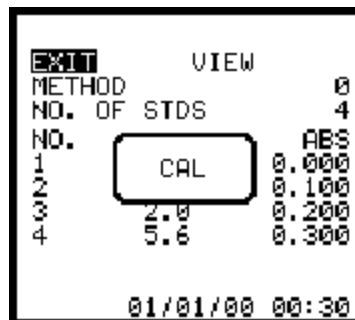

and the instrument display will update to show the following:



Each time a calibration is performed the display will momentarily show **MEASURING**

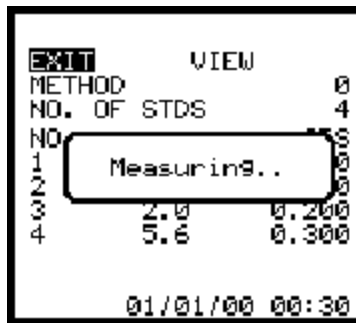

and then update, requesting the next standard to be placed in the sample chamber until the specified number of standards has been calibrated.

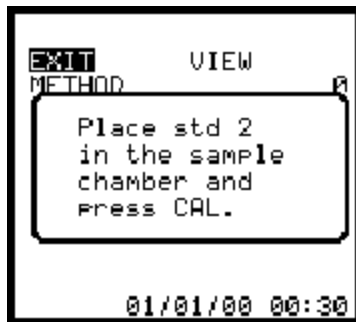

If it is necessary to abort the calibration sequence before all standards have been measured, this can be carried out by pressing any keys other than **CAL** or **ENTER**. Only information entered up to that point will be retained.

Once entry of these values is completed, selection of the **VIEW** option will allow the user access to the graphical calibration curve constructed from these values. An X displayed on the graph indicates the position of a calibration point.

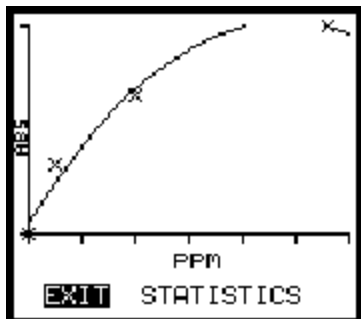

Selecting **STATISTICS** from this menu will show the terms used for the calculated quadratic curve fit. The curve fit is of the form $y = ax^2 + bx + c$, so the statistics page shows the ax^2 , bx and c terms separately.

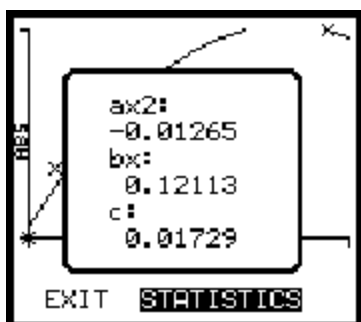

Pressing any key again allows the user to view the x and y min/max values (i.e. the axis limits to which the graph is plotted). The x-axis = concentration; the y-axis = absorbance.

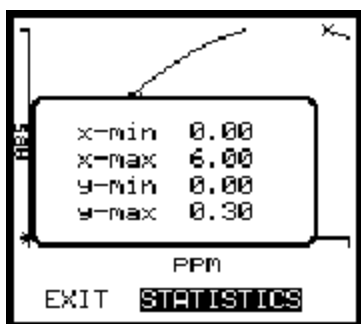

If unlocked it is possible to adjust/amend the standard or Absorbance values by using the right arrow key to move over to Absorbance values.

Performing a measurement

- Press any key to clear the above screen.
- Select EXIT to clear the graphical screen.
- Select EXIT again to return to the main measurement screen.

Place a sample blank into the sample chamber and close the sample chamber lid. Press the **CAL** key to initiate a calibration.

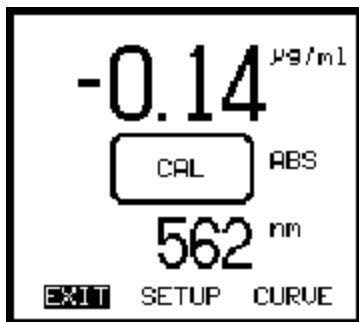

Remove the sample blank from the sample chamber and replace with the unknown sample. The Absorbance value is read and plotted against the curve to determine the concentration value. This value is presented in large figures at the top of the screen.

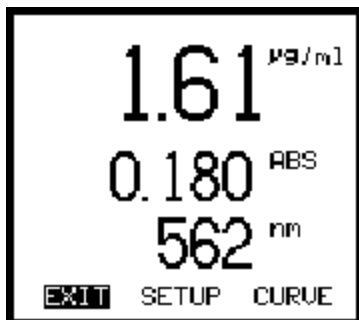

3.7 DIRECT UV

This measurement mode differs from the other 4 in that it does not use a calibration curve for measurement, but requires readings at 280 and 260nm and an answer calculated based on: $A_{280} \times 1.55 - A_{260} \times 0.76$. Measurements can be made using 280nm only. In this instance, the Factor 1 value should remain as set (1.550), and the Factor 2 value should be set to 0.000.

Select **DIRECT UV** from the Protein mode. The following display will be shown:

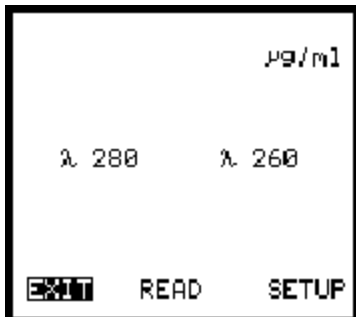

Select the **SETUP** option:

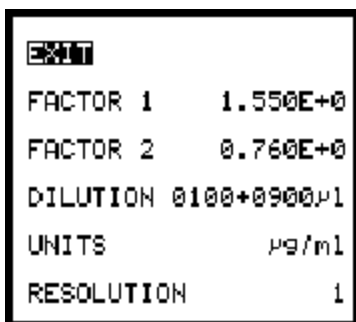

- EXIT** Allows user to exit this menu
- FACTOR 1** Value at which the Abs at 280nm gets multiplied by
- FACTOR 2** Value at which the Abs at 260nm gets multiplied by.
- User adjustable calculation factors are displayed as exponential values (E-3, E+0, E+3, etc.) depending on the units of measure, mantissa only is user adjustable
- DILUTION** Allows the user to directly obtain the concentration of the original solution. Enter the volume of the sample solution in µl. Move the cursor to the right using the arrow key and enter the volume of the diluent in µl. Use the enter key to store these values and return to the options listing. To obtain an accurate result ensure the solution is thoroughly mixed prior to measurement.
- UNITS** Allows the user to select the preferred measurement unit (µg/ml, mg/ml, ng/ml, ng/µl, g/dl, mg/dl)
- RESOLUTION** Allows the user to select the preferred resolution (1, 0.1, 0.01 or 0.001).
The final figure shown will be reduced in resolution if it not possible to show all the required decimal places on the screen.

If the **READ** option is selected prior to performing a calibration the following message will be displayed:



When all set up parameters have been entered, exit this option. Place a sample blank into the sample chamber and close the lid. Press **CAL** and the instrument will calibrate at 280 and 260nm (even when only 280nm is required).

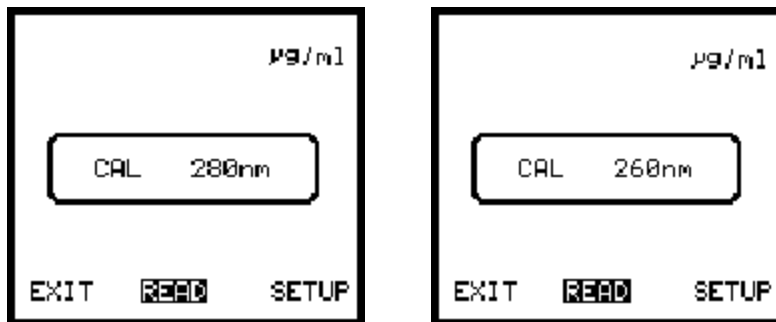

The display will update to show zero at both points:

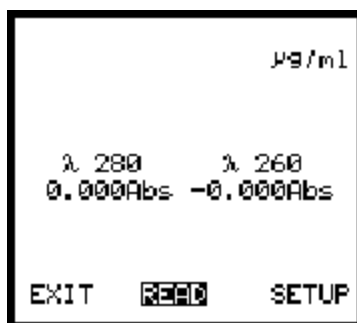

Remove the sample blank from the chamber and insert the unknown sample. Close the sample chamber lid. Select **READ** and the instrument will measure at both points (even when only 280nm is required):

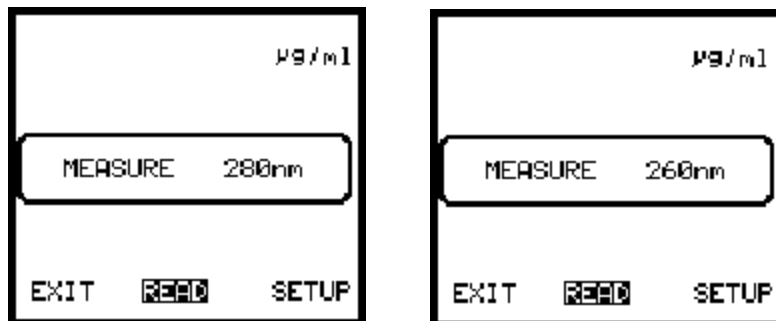

Once the measurement sequence has been successfully performed, the display will update to show the final sample reading.



3.8 DNA/RNA MODE

Select the **DNA/RNA MODE** option from the main menu:



Set up and measurement procedures are the same for **260/280nm** and **260/230nm** modes, as detailed below. Select the appropriate mode of operation: **260/280nm** or **260/230nm** and the following screen will be displayed:

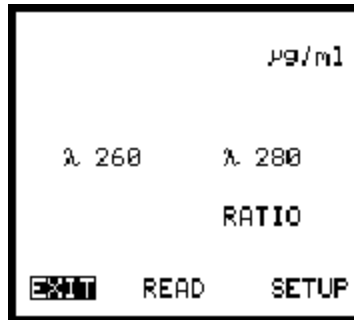

Select **SETUP** and the following menu will be displayed:

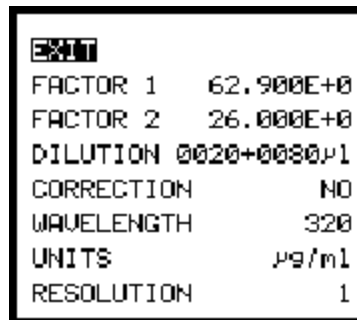

EXIT	Allows the user to exit this menu
FACTOR 1	Value at which the Abs at 260nm gets multiplied by
FACTOR 2	Value at which the Abs at either 230 or 280nm gets multiplied by
DILUTION	User adjustable calculation factors are displayed as exponential values (E-3, E+0, E+3, etc.) depending on the units of measure, mantissa only is user adjustable Allows the user to directly obtain the concentration of the original solution. Enter the volume of the sample solution in µl. Move the cursor to the right using the arrow key and enter the volume of the diluent in µl. Use the enter key to store these values and return to the options listing. To obtain an accurate result ensure the solution is thoroughly mixed prior to measurement.
CORRECTION	YES/NO option. A reference wavelength is optional. If this is to be used in calculations then YES should be selected
WAVELENGTH	If the correction option is set to yes, then the wavelength must be specified
UNITS	Allows the user to select the preferred measurement unit (µg/ml, mg/ml, ng/ml, ng/µl).
RESOLUTION	Allows the user to select the preferred resolution (1, 0.1, 0.01 or 0.001). The final figure shown will be reduced in resolution if it not possible to show all the required decimal places on the screen.

When all set up parameters have been entered, exit this option.

If the **READ** option is selected prior to performing a calibration the following message will be displayed:

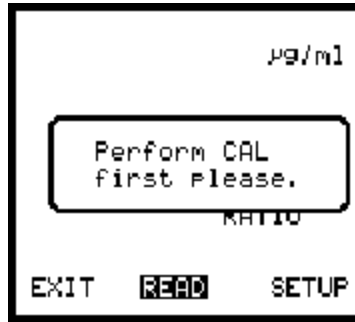

Place a sample blank into the sample chamber and close the lid. Press **CAL** and the instrument will calibrate at **260/280nm** or **260/230nm**, depending on the mode selected.



If the reference wavelength option is selected a third calibration will be performed at the nominal reference wavelength of 320nm. All 3 values will be shown on the instrument display.

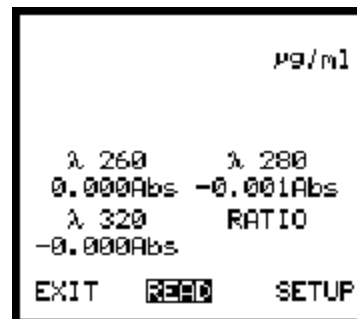
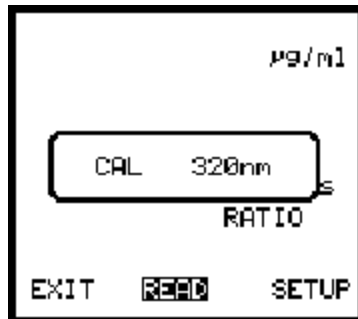

The DNA calculation will be performed by reading the absorbances at the required wavelengths and calculating the answer based on the pre-entered factors.

Remove the sample blank from the chamber and insert the unknown sample. Close the sample chamber lid. Select **READ** and the instrument will measure at 2 or 3 points, depending on selection/non-selection of reference wavelength option.



Once the measurement sequence has been successfully performed, the display will update to show the final sample reading.

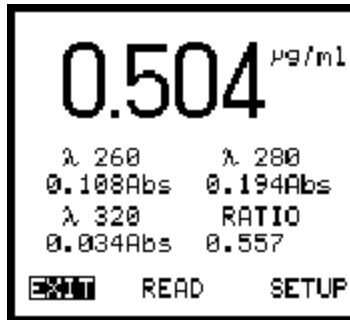

VARIABLE RATIO

This mode operates in the same way as the **260/280nm** and **260/230nm** modes, with the additional benefit of the ability to specify wavelength values where peaks are not at 260/280 or 260/230. This enables fine adjustment for greater accuracy.

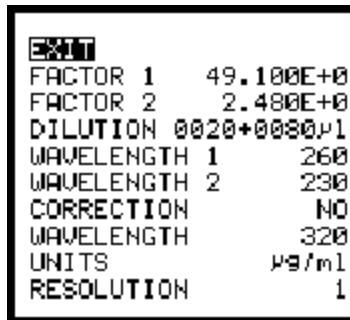

EXIT

Allows the user to exit this menu

FACTOR 1

Value at which the Abs at Wavelength 1 gets multiplied by

FACTOR 2

Value at which the Abs at Wavelength 2 gets multiplied by

User adjustable calculation factors are displayed as exponential values (E-3, E+0, E+3, etc.) depending on the units of measure, mantissa only is user adjustable

DILUTION

Allows the user to directly obtain the concentration of the original solution. Enter the volume of the sample solution in μl . Move the cursor to the right using the arrow key and enter the volume of the diluent in μl . Use the enter key to store these values and return to the options listing. To obtain an accurate result ensure the solution is thoroughly mixed prior to measurement.

WAVELENGTH 1

Allows adjustment of the first wavelength value (260)

WAVELENGTH 2

Allows adjustment of the second wavelength value (230)

CORRECTION

YES/NO option. A reference wavelength is optional. If this is to be used in calculations then YES should be selected

**WAVELENGTH
UNITS**

If the correction option is set to yes, then the wavelength must be specified
Allows the user to select the preferred measurement unit ($\mu\text{g/ml}$, mg/ml , ng/ml ,
 $\text{ng}/\mu\text{l}$, g/dl , mg/dl).

RESOLUTION

Allows the user to select the preferred resolution (1, 0.1, 0.01 or 0.001).
The final figure shown will be reduced in resolution if it not possible to show all the
required decimal places on the screen.

PURITY SCAN

This mode provides a graphical representation of the Abs range and determines the peak absorbance. It allows
a sample to be scanned (absorbance versus wavelength) 50nm either side of a user entered centre wavelength
(250-950nm) at 1nm steps.

Select the **PURITY SCAN MENU**

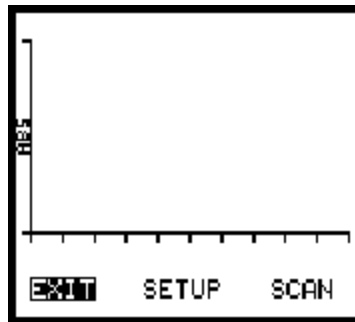

The following display will then be shown:

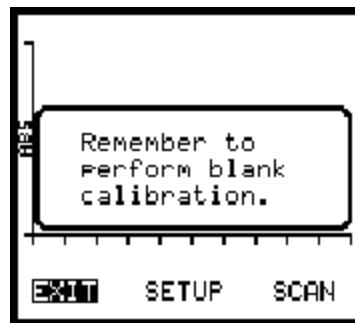

Select **SETUP** and adjust the wavelength value as appropriate for the test being performed.

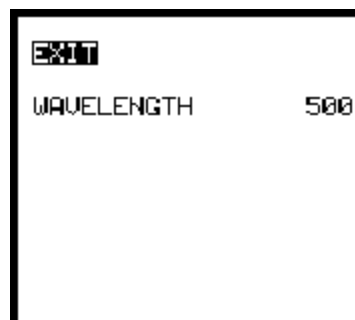

When the required wavelength value has been entered and confirmed, place a sample blank into the sample chamber and close the lid. Press **CAL** and the instrument will perform a calibration as shown.

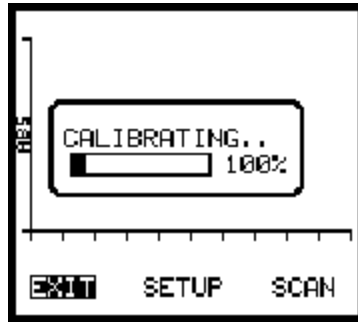

Remove the sample blank from the sample chamber and insert the unknown sample. Close the sample chamber lid. Select **SCAN**. The instrument will perform the scan as shown.

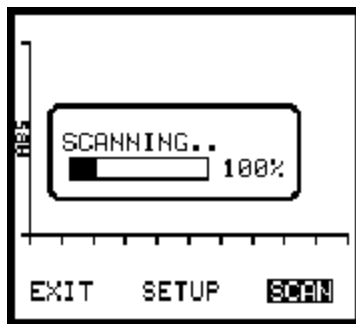

Once the scan is completed the instrument will analyse the data and determine the peak point.

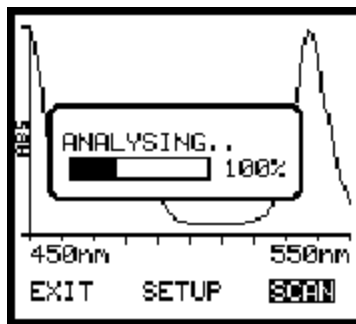

The display will then update to show peak absorbance and the wavelength of the peak.

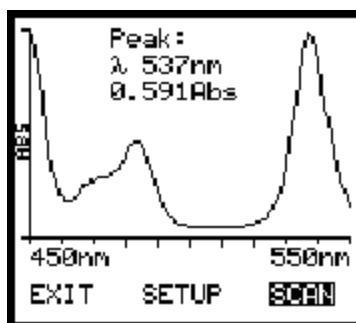

dsDNA, ssDNA, RNA and OLIGO MODES

NOTE: These 4 modes, although using different factor values, are all performed using the same procedures as detailed below. Measurement method is Photometrics. Absorbance, %T and Concentration values are displayed simultaneously, i.e; they are not individually selectable.

Select the appropriate measurement mode from the main menu and the following display will be shown:

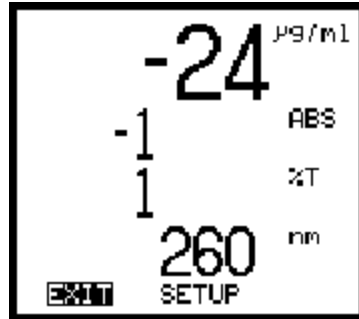

Select **SETUP**

dsDNA factor value

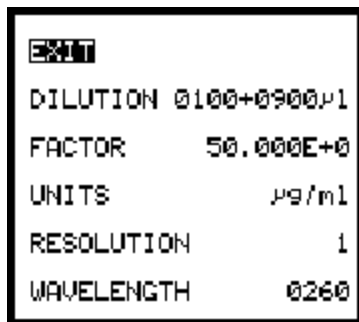

ssDNA factor value

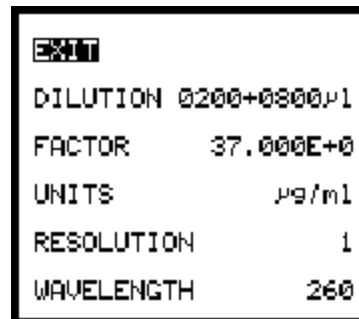

RNA factor value

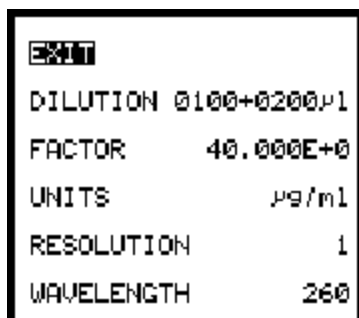

OLIGO factor value

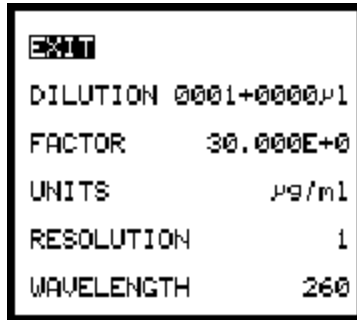

EXIT	Allows the user to exit this menu
DILUTION	Allows the user to directly obtain the concentration of the original solution. Enter the volume of the sample solution in µl. Move the cursor to the right using the arrow key and enter the volume of the diluent in µl. Use the enter key to store these values and return to the options listing. To obtain an accurate result ensure the solution is thoroughly mixed prior to measurement.
FACTOR	Used for the concentration calculation where concentration = Factor x Abs. User adjustable calculation factor is displayed as an exponential value (E-3, E+0, E+3, etc.) depending on the units of measure, mantissa only is user adjustable)
UNITS	Allows selection of the units used to display against the concentration reading. The choice available: µg/ml, ng/ml, mg/ml, ng/µl.
RESOLUTION	Allows the user to specify the resolution of the displayed reading (1, 0.1, 0.01, 0.001). The maximum resolution that concentration readings are displayed to can be set up to 3 decimal places. The instrument will automatically display concentration readings to the maximum possible resolution using this parameter.
WAVELENGTH	Allows user setting of preferred wavelength for the test being performed.

Performing a measurement

To perform a measurement it is necessary to calibrate the unit first.

Place a blank solution into the sample chamber and close the lid. Press the **CAL** key.

The instrument will momentarily show **CAL** indicating that the calibration is being performed.

Once calibrated, the display values will update to show ABS, %T and Concentration readings.

Remove the blank solution from the sample chamber.

The instrument is now ready to perform a measurement. The instrument will now continually perform a live measurement.

The sample value will be shown directly as ABS, %T and Concentration.

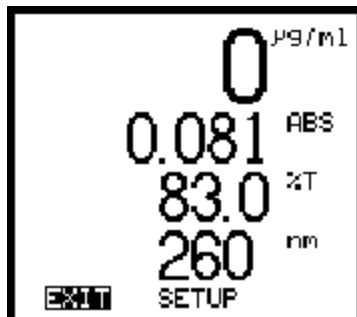

3.9 GOOD PRACTICE GUIDELINES

1. To ensure accurate results are obtained the sample area lid should be kept in the closed position during measurement.
2. The styrene cuvettes supplied with the unit are disposable (i.e. ideally they should be used once and then thrown away). Some repeat use is possible, providing extreme care is taken during cleaning, to ensure no damage occurs to the polished surface.
3. Plastic cuvettes are not suitable for use with organic solvents.
4. Glassware used in the preparation of standards should be of high grade borosilicate glass. The use of soda glass should be avoided where possible as leaching can occur during prolonged contact, giving erroneous results.
5. Glass cuvettes should be thoroughly cleaned after use. Discard when scratches become evident in polished surfaces.
6. Chemical reagents should, wherever possible, be of high grade quality. Contamination can cause problems, even at very low levels. Diluents (i.e. water or solvents) must be free from impurities.
7. There are some substances which do not follow Beer's Law. When attempting a new method it is advised that linearity checks should be performed over the range of concentrations being used. This can be carried out by preparing a quantity of known strength solutions and checking the results.
 - a) Deviations from Beer's Law may occur at high concentrations by association of molecular ionic species.
 - b) Deviations from Beer's Law may occur at low concentrations by variation in hydration, introducing changes in the nature of complex ions.
 - c) Absorption which does not obey Beer's Law will require a graph of known standards to be plotted. This should indicate Reading vs Concentration. The reading obtained from the unknowns can then be related to the concentrations from the graph.
8. Samples and standards can "outgas" when left in the cuvette. Bubbles formed on the cuvette walls will cause reading errors.

SECTION 4

MAINTENANCE

4.1 GENERAL

The Genova is designed to give optimum performance with minimal maintenance. It is only necessary to keep the external surfaces clean and free from dust. The sample area should always be kept clean and any accidental spillage should be wiped away immediately. To give added protection when not in use the unit should be disconnected from the mains supply and covered with the optional dust cover (630 028). For longer term storage or re-shipment it is recommended that the unit be returned to its original packing case.

NOTE: The Genova monochromator is a non-serviceable unit and no attempt should be made to repair this item. Failure to observe this recommendation will result in the loss of any Warranty Claim on this product. In the unlikely event of the monochromator requiring service or calibration, it is essential that the manufacturer or your local distributor be contacted immediately for advice.

4.2 LIGHT SOURCE REPLACEMENT

The only routine maintenance which may be required is the replacement of the light source if this fails. Failure should be suspected if the instrument fails wavelength calibration during initialisation or the instrument is unable to calibrate to zero absorbance when the CAL key is pressed. The message "LIGHT LEVEL TOO LOW" will be displayed. The xenon flash lamp module is available from the manufacturer or your local distributor – refer Section 5.2 Spares.

CAUTION: The following safety precautions should be observed prior to attempting the light source replacement procedure.

- 1. DISCONNECT THE UNIT FROM THE MAINS SUPPLY PRIOR TO REMOVING THE TOP COVER.**
- 2. SAFETY GLASSES MUST BE WORN WHEN UV EMISSIONS ARE PRESENT.**
- 3. DO NOT TOUCH THE LIGHT OUTPUT MODULE OF THE LAMP MODULE.**

1. Remove the 4 case screws as shown.
2. Lift the top cover clear, taking care not to strain the ribbon cable.
3. Remove the 2 xenon lamp retaining thumb screws.
4. Remove the connector from the rear of the xenon lamp.
5. When replacing the lamp ensure it is pushed fully up into the optics housing before tightening the thumb screws.
6. Refit the top cover, taking care with the ribbon cable. Refit the 4 case screws.

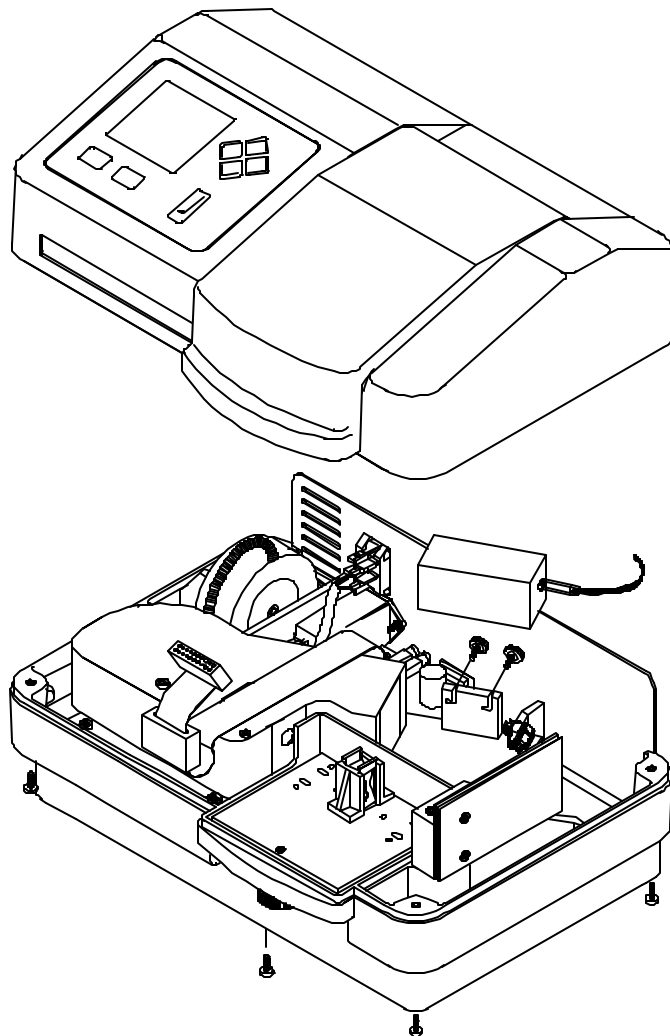

SECTION 5

OPTIONAL ACCESSORIES

5.1 OPTIONAL ACCESSORIES

The following list of items is available for use with the Genova:

636 041	Capillary micro sample holder
035 134	Pack 100 micro capillaries (200 – 900nm)
060 377	Cristaseal (pack 10)
035 132	Pack 100 (500µl) UV plastic cuvettes (220 – 900nm)
632 001	Sipper pump (230V version)
632 031	Sipper pump (115V version)
634 001	4 position cell holder
021 041	DC/AC power converter
630 020	Test tube block (13mm diameter)
630 021	Test tube block (25mm diameter)
630 022	Test tube block (16mm diameter)
630 005	20 - 100mm cell holder
035 079	100 x 10mm glass cell
035 087	50 x 10mm glass cell
035 029	40 x 10mm glass cell
035 086	20 x 10mm glass cell
035 027	10 x 10mm glass cell
060 087	Pack 100 (1ml) plastic semi-micro cuvettes (320 – 1100nm)
060 084	Pack 100 (3.5ml) plastic cuvettes (320 – 1100nm)
060 229	Pack 500 (3.5ml) plastic cuvettes (320 – 1100nm)
630 028	Dust cover
035 088	Calibration set

5.2 SPARES

012 094	Xenon lamp module
630 004	10 x 10mm cell holder
016 021	Replacement fuse 2A

SECTION 6

INTERFACING

6.1 SERIAL INTERFACE

The Genova has a bi-directional RS232 interface set to:

1200 baud
7 data bits
odd parity
1 stop bit

The 25 way D connector allows a standard one-to-one interconnection lead to be used, as supplied with the 40 column printer.

A printout is initiated by pressing the PRINT key. If the sample number is unity, then the printout will include a header block. The sample number is incremented every time the print key is pressed.

The following commands can also be sent to the Genova via the serial interface.

ASCII D or d	Sames as pressing the print key
ASCII T<CR>	Outputs transmission and wavelelength separated by an ASCII TAB character, regardless of the Genova operating mode. For example; 100.0 540
ASCII A<CR>	Outputs absorbance and wavelength separated by an ASCII TAB character, regardless of the Genova operating mode. For example; 0.001 540
ASCII C<CR>	Outputs concentration and wavelength separated by an ASCII TAB character, regardless of the Genova operating mode. For example: 123.4 540
ASCII V<CR>	Outputs a voltage proportional to the monochromatic light level passing through the sample and wavelength separated by an ASCII TAB character. For example; 1234.5 540
ASCII Z<CR>	Calibrates a zero absorbance if the xenon lamp is on (SO<CR> command), or zero transmittance if the lamp is off (SC<CR> command)
ASCII SC<CR>	Switches the xenon lamp off. This allows 0% transmittance to be calibrated
ASCII SO<CR>	Switches the xenon lamp on. This allows 100% transmittance (zero absorbance) to be calibrated. The lamp must be on for normal measurements.
ASCII Gnnn<CR>	Commands the Genova to go to the wavelength nmm. For example; G540<CR> will set the wavelength to 540nm
ASCII Fxxxx.x<CR>	Sets the concentration factor to xxxx.x. For example; F1000<CR> will set the factor to 1000

NOTE <CR> is an ASCII carriage return character.

The commands provide an output which can readily be incorporated into most spreadsheet software packages.

6.2 RS232 OUTPUT

The bi-directional RS232 interface is available on the rear panel 25 way D connector. The connections are as follows:

TXD 2	-INPUT TO GENOVA
RXD 3	-OUTPUT FROM GENOVA
RTS 4	-LINKED TO CTS
CTS 5	-LINKED TO RTS
DSR 6	-OUTPUT FROM GENOVA
DCD 8	-OUTPUT FROM GENOVA
DTR 20	-INPUT TO GENOVA (must be active)

Suggested interconnections are detailed below:

GENOVA	IBM PC XT (25 way "D")
TXD 2	2 TXD (From PC)
RXD 3	3 RXD (To PC)
RTS 4	4 RTS (From PC)
CTS 5	5 CTS (To PC)
DSR 6	6 DSR (To PC)
DCD 8	8 DCD (To PC)
DTR 20	20 DTR (From PC)
GND 7	7 GND

GENOVA	IBM PC XT (9 way "D")
TXD 2	3 TXD (From PC)
RXD 3	2 RXD (To PC)
RTS 4	7 RTS (From PC)
CTS 5	8 CTS (To PC)
DSR 6	6 DSR (To PC)
DCD 8	1 DCD (To PC)
DTR 20	4 DTR (From PC)
GND 7	5 GND

NOTE: The interface cable kit (order code 542 009) can be used to implement the above connections.

6.3 RECORDER OUTPUT

This is available via the 4mm rear panel sockets. The level is proportional to the displayed concentration reading.

Concentration 1mV per concentration unit

EC Declaration of Conformity

The Jenway Genova complies with the following European Standards:

EN 61326:1998 Electrical equipment for measurement, control and laboratory use – EMC requirements.

EN 61010-1:1993 Safety requirements for electrical equipment for measurement, control and laboratory use.

Following the provision of:

EMC Directive – 89/336/EEC and
Low Voltage Directive – 73/23/EEC

Martyn J. Fall
Managing Director, Jenway Limited,
Gransmore Green, Felsted, Dunmow,
Essex, CM6 3LB, England

References

Method	References
PROTEIN	
Lowry	Lowry, O. H., Rosebrough, N.J., Farr, A. L. and Randall, R. J. (1951) <i>J. Biol. Chem.</i> , 193 , 265-275
BCA	Smith P.K., Krohn, R.I., Hermanson, G.T., Mallia, A.K., Gartner, F. H., Provenzano, M. D., Fujimoto, E. K., Goeke, N. M., Olson, B. J. and Klenk, D. C. (1985) <i>Anal. Biochem.</i> , 150 , 76-85
Bradford	Bradford, M. (1976) <i>Anal. Biochem.</i> , 72 , 248-254
Biuret	Ohnishi, S. T., Barr, J. K. <i>Anal Biochem</i> , 86, 193 (1978)
DNA MEASUREMENT	
DNA Purity	Layne, E. (1951) <i>Methods in Enzymology</i> , 3, 447-454
Absorbance difference (260, 280)	Groves, W. E., Davis, F. C. and Sells, B. H. (1968) <i>Anal. Biochem.</i> , 22, 195-209 Warburg, O., Christian, W. (1941) <i>Biochem. Z.</i> , 310, 384
Absorbance difference (260, 230)	Kalb, V. F., Bernlohr, R. W. (1977) <i>Anal. Biochem.</i> , 82, 362-371
Direct UV DNA MEASUREMENT	Maniatis, T., Fritch, E. F., Sambrook, J. (1989) <i>Molecular Cloning: A Laboratory Handbook</i> , 3